



WORK SESSION
Upper Level Conference Room
5:30 PM

WAITE PARK CITY COUNCIL AGENDA
MONDAY, SEPTEMBER 18, 2017
6:30 PM

6:30 P.M. Pledge of Allegiance
Open Forum – two minute limit

Review and approve, September 18, 2017 Council Agenda

1. Consent Agenda:
Recommended action: approval of following items
 - A. Approve Minutes of August 21, 2017
 - B. Approve Minutes of September 6, 2017
 - C. Approve Change Order for Public Works Project
 - D. Approve Purchase of Defibrillators
2.
 - A. Approve 2018 General Fund Preliminary Budget and Levy
 - B. Approve 2018 Rural Tax Rates
3. Conditional Use Permit – Expansion of St. Cloud Toyota into Former Dunham’s Space – 400 2nd Street S
4. Conditional Use Permit – Novel Solar Two LLP and Gary M. & Jodi A. Schneider Trust – Vicinity of CR 138 and I-94
5. Public Nuisance Abatement – Property at 212 5th Avenue N
6. Poganski Automotive CUP – 408 3rd Street N
7. Water Tower Maintenance Agreement Contract
8. Payoff Lienholder on Forfeited Vehicle
9. Council/Mayor
 - A. Review and Approve Bills
10. Administrator
 - A. Updates

ADJOURN

**CITY OF WAITE PARK
CALL TO ORDER –**

**PLEDGE OF ALLEGIANCE
OPEN FORUM**

Review and Approve September 18, 2017 City Council Agenda

Councilmember _____ moved that the Council Agenda for September 18, 2017 be approved as presented.

Councilmember _____ seconded the motion.
Motion (Approved) (Denied)

Agenda Item No. 1-Consent Agenda

1. Consent Agenda:

Recommended action: approval of following items

- A. Approve Minutes of August 21, 2017
- B. Approve Minutes of September 6, 2017
- C. Approve Change Order for Public Works Project
- D. Approve Purchase of Defibrillators

Councilmember _____ moved that the Consent Agenda, as presented, be approved.

Councilmember _____ seconded the motion.

ROLL CALL

Councilmember Michael Linquist _____
Councilmember Charles Schneider _____
Councilmember Vic Schulz _____
Councilmember Frank Theisen _____
Mayor Richard Miller _____

Motion (Approved) (Denied)

WAITE PARK CITY COUNCIL MEETING

AUGUST 21, 2017

A meeting of the Waite Park City Council was held at Waite Park City Hall on Monday, August 21, 2017 beginning at 6:30 PM.

MEMBERS PRESENT

Members present were Mayor Miller, Councilmembers Linquist, Schneider, Schulz and Theisen

CITY REPRESENTATIVES PRESENT

City Representatives present were City Administrator Johnson, Deputy Clerk-Treasurer Virnig, Public Works Director Schluenz, Planning and Community Development Director Noerenberg, Attorney Hansmeier

OTHERS PRESENT

There were no signatures on an attendance sheet.

OPEN FORUM

Mayor Miller invited anyone wishing to speak during the open forum to step forward, but no one came forth.

COUNCIL AGENDA

Motion by Member Theisen, second by Member Schulz, to approve the 8/21/17 Council Agenda as presented. The motion carried unanimously.

1. CONSENT AGENDA

Motion by Member Schulz, second by Member Theisen, to approve the following 8/21/17 Consent Agenda items:

- 1.A. Approved Council Minutes of August 7, 2017
- 1.B. Approved St. Joseph One-Day Liquor License
- 1.C. (Pulled for discussion – regarding Maintenance Worker Appointment)
- 1.D. Approved Resolution Calling for Public Hearing on Proposed Establishment of Development of District No. 3 (**RESOLUTION NO. 082117-01**)

The motion carried unanimously.

1.C. MAINTENANCE WORKER APPOINTMENT

Motion by Member Schneider, second by Member Theisen to make a conditional employment offer to Shane Barclay for the position of maintenance worker subject to background check beginning at Step 1, Pay Grade 4 and with successful employment evaluation, Step 2 after six months and Step 3 after one year.

Ayes: Mayor Miller, Members Schneider, Schulz, Theisen

Nays: Member Linquist

Abstained: None

The motion carried.

2. COUNCIL/MAYOR

2.A. REVIEW AND APPROVE BILLS

Motion by Member Linquist, second by Member Schneider, to authorize payment of the accounts payable list (0517M1, 0517M2, 0817D1). The motion carried unanimously.

Mayor Miller thanked staff for a good job on the amphitheater bonding presentation last week.

3. ADMINISTRATOR

3.A. UPDATE

City Administrator Johnson reviewed the following:

- There will be a Joint Cities Meeting in St. August on August 29, 2017 and discussion will be held on increasing the smoking age to 21.
- There will be a Budget Work Session on September 6, 2017 and possibly a council meeting that same day.
- The next regular Council Meeting will be on Monday, September 18, 2017.
- The Council Chambers remodel should be completed around the end of August.
- There is a ground breaking ceremony at Rivers Edge Park for the Lake Wobegon Trail on Tuesday, August 22, 2017 at 1:30 p.m.
- Staff is working on the Hotel Ordinance and it may be presented at the first Council Meeting in October.
- An intern from the MPA program at St. Cloud State University will be interning with the City of Waite Park for the school year. St. Cloud State University will be paying for this internship.

ADJOURNMENT

Mayor Miller declared the meeting adjourned at 6:36 p.m.

Richard E. Miller
Mayor

Shaunna Johnson
City Administrator

WAITE PARK CITY COUNCIL MEETING

SEPTEMBER 6, 2017

A meeting of the Waite Park City Council was held at Waite Park City Hall on Wednesday, September 6, 2017 beginning at 4:00 PM.

MEMBERS PRESENT

Members present were Mayor Miller, Councilmembers Linquist, Schneider, Schulz and Theisen

CITY REPRESENTATIVES PRESENT

City Representatives present were City Administrator Johnson, Chief of Police Bentrud, Public Works Director Schluenz, Planning and Community Development Director Noerenberg, Attorney Erickson, SEH Engineer Wotzka

OTHERS PRESENT

There were no signatures on an attendance sheet.

OPEN FORUM

Mayor Miller invited anyone wishing to speak during the open forum to step forward, but no one came forth.

COUNCIL AGENDA

Motion by Member Theisen, second by Member Schneider, to approve the 9/6/17 Council Agenda as amended.

- 1.C. (Add) Police Officer Hiring
- 1.D. (Add) Grant Application for Central MN Sex Trafficking Task Force

The motion carried unanimously.

1. CONSENT AGENDA

Motion by Member Schulz, second by Member Theisen, to approve the following 9/6/17 Consent Agenda items:

- 1.A. Approved Resolution for Off-Site Gambling Permit for St. Joseph's Church
(RESOLUTION NO. 090617-01)
- 1.B. Approved Change Order #4 for 17th Avenue
- 1.C. (Pulled for discussion – regarding Police Officer Hiring)
- 1.D. (Pulled for discussion – regarding Grant Application for Central MN Sex Trafficking Task Force)

The motion carried unanimously.

1.C. POLICE OFFICER HIRING

Motion by Member Schneider, second by Member Theisen, to approve hiring a police officer in the 2017 budget. The motion carried unanimously.

1.D. GRANT APPLICATION FOR THE CENTRAL MN SEX TRAFFICKING TASK FORCE

Motion by Member Schneider, second by Member Theisen, to approve applying for a grant with the Central MN Sex Trafficking Task Force. The motion carried unanimously.

2. PLANS AND SPECIFICATIONS FOR GRANITEVIEW ROAD AND AUTHORIZE FOR BIDS

Bids were opened on August 31, 2017. A tabulation of bids was presented. The low bid was submitted by Omann Contracting Companies, Inc. of Albertville, MN in the amount of \$149,175.99. A letter of recommendation to award the bid to Omann Contracting Companies, Inc. in the amount of \$149,175.99, to be funded by the General Fund Reserve.

Discussion was held on improvements to this road and other road improvements in the future.

Motion by Member Schneider, second by Mayor Miller, to approve the 2017 Graniteview Road Project to Omann Contracting Companies, Inc. in the amount of \$149,175.99 as presented. More discussion was held on improvements to this road versus other roads.

Ayes: Mayor Miller, Members Schneider, Schulz

Nays: Members Linquist, Theisen

Abstained: None

The motion carried.

3. ADMINISTRATOR

3.A. UPDATE

City Administrator Johnson did not have any updates at this time.

ADJOURNMENT

Mayor Miller declared the meeting adjourned at 4:13 p.m.

Richard E. Miller
Mayor

Shaunna Johnson
City Administrator

Consent Agenda Item C: Approve Change Order for Public Works Project

See attached.



1795 SAINT CLAIR AVENUE, SAINT PAUL, MN 55105

TEL: 651/696-5186

Date: June 28, 2017

To: Bill Schluenz

From: Jeff Oertel

RE: Request for additional fee / services

MEMORANDUM

I had mentioned a while ago that we had some unanticipated time to assist with various items for the project, not part of our original work, or items that were designed and changed during construction. As we near the end of the job, I think that this will be all there is. Unless there is something major, I do not expect to request more fee. This memo is a summary of what I think is reasonable.

I did not include things like special meetings, trouble-shooting the granite, issues with the lift, field conditions and that sort of thing, as these kinds of things are a means of getting the job done.

At this point, just call it a request, subject to review and consideration by council.

The items that were changed or added typically involved some drawing, preparation of forms, discussion and review.

Item	Hours	Average rate	Total	Other / comments
Added doors/frames in corridor	4	\$110.00 / hour	\$440.00	Added during construction
Wash bays items	8	\$150.00 / hour	\$1,200.00	Trouble-shooting electrical, concrete, rail extensions; memos and telecoms
Water salesman building / site	18	\$110.00 / hour	\$1,980.00	Added entire building and related sitework during construction
Furniture	24	\$70.00 / hour	\$1,680.00	Assistance with selection of tables, chairs, etc.; meetings, reviews
Finishes	6	\$70.00 / hour	\$420.00	Changes to finishes at start of construction; new selections, meetings, research, etc.
Site changes	7	\$110.00 / hour	\$770.00	Various changes/requests for fuel location, fence, landscaping, water salesman, etc.
Minor items	10	\$110.00 / hour	\$1,100.00	Adds/changes for precast plank, lighting, hardware, drains, paint, bollards, etc.
Total			\$7,590.00	

Consent Agenda Item D: Approve Purchase of Defibrillators

Each patrol vehicle within the police department is equipped with an Automated External Defibrillator (AED). Each officer of the department is trained to use AED's in the event of a cardiac incident while responding to medical calls. The department has \$7,500.00 allocated in its 2017 budget for the replacement of older department AED's. The cost to purchase five (5) AED's from Cardiac Science is \$5,975.00.

This purchase would also mean that the department has the same AED unit in each squad car. Currently we are using three different brands of AED. Accordingly, this uniformity in equipment is advantageous when it comes to training in proper AED use, purchasing the replacement batteries and other AED supplies.



Purchase Agreement

Monday, August 28th, 2017

Territory Manager: Matt Fox

CUSTOMER BILLING INFORMATION

Waite Park Police Department
19 13th Ave N.
PO Box 339
Waite Park, MN 56387
Stearns County
Rescue Ready® Services Lead:
P: E:

Tim Deschene
Sergeant
320-251-3281 P
F
tim.deschene.ci.waiteparkpd.mn.us

Invoice to: Individual Location

Payment terms: Net 30 Tax exemption #: 41-100051008 P.O. #: Not Applicable Code: _____

Customer, please fill out this section:

Payment choice: Check C.O.D. Bank wire Visa Mastercard Amex

Card Number

Expiration Date

Security Code

Class ID: Price Code: Cntrct-NASPO Lead: Referral Affiliation: NASPO

CUSTOMER SHIPPING INFORMATION

Customer: Waite Park Police
Department
Address 1: 19 13th Ave N.

Contact Name: Tim Deschene
Title: Sergeant

Address 2:

Phone: 320-251-3281

City: Waite Park

Fax:

State: MN

Email:

Zip: 56387

tim.deschene.ci.waiteparkpd.mn.us

Shipping Method: FedEx - Ground

County: Stearns County

Freight Account #:

FOB: Destination

PRODUCT DESCRIPTION	QTY	LIST PRICE	UNIT PRICE	SUB TOTAL
G3 Plus Semi-Automatic Package (9390E-1001P): Powerheart AED G3 Plus Semi-Automatic Package, AHA/ERC 2010 Guidelines Compliant. Package includes: (1) 9390E Powerheart AED G3 Plus Semi-Auto; (1) 9146 IntelliSense Battery; (2) pairs 9131 adult defibrillation pads; (1) carry bag; (1) 5550 ready kit; (1) Quick Start Tool Kit (includes Quick Start Guide, CD-ROM with AED manual, training video, RescueLink & MDLink); (1) serial communications cable	5	1895.00	1195.00	5975.00

SUBTOTAL	5975.00
* SALES TAX	0.00
SHIPPING	TBD
GRAND TOTAL	5975.00
	\$

* Estimated sales tax only. Sales tax subject to change upon review.

Please send purchase orders and
correspondence to:

Fax to: 262-953-3499

Please send payment to:
Cardiac Science Corporation
PO BOX 776401
Chicago, IL 60677-6401

Cardiac Science Corporation
N7 W22025 JOHNSON DRIVE
WAUKESHA, WI 53186
Tel: +1.800.426.0337

**BY SIGNING THIS AGREEMENT, CUSTOMER REPRESENTS THAT THEY ARE AUTHORIZED TO PURCHASE AND AGREES TO
CARDIAC SCIENCE TERMS & CONDITIONS.** AEDs are intended for use by or on order of a physician or persons licensed by state law.

I HAVE READ AND AGREE TO CARDIAC SCIENCE'S TERMS AND CONDITIONS.

Authorized Signature

Dave Bentrud
Print Name

Chief
Title

8-30-17
Date

General Comments:

TERMS AND CONDITIONS

These Terms and Conditions together with this agreement between Buyer and Cardiac Science shall apply to the sale to Buyer of all goods (including AEDs, oxygen, first-aid kits and other goods) and services (including training, consultation, maintenance and other services) purchased hereunder.

- 1. Terms and Conditions.** This Agreement sets forth the sole and entire agreement between the parties regarding the sale of goods and services herein and supersedes any contemporaneous oral agreements between them regarding the same. Any alteration to these terms and conditions shall be effective only if made in writing and signed by authorized representatives of both parties. Facsimile signatures shall be effective to bind either Party to the terms hereof.
- 2. Payment, Price & Acceptance.** All sales are final and payment for products and services are due upon receipt of invoice, unless otherwise specified on the order. All prices are F.O.B. Cardiac Science's designated shipping point. Title and risk of loss shall transfer from Cardiac Science to Buyer at Cardiac Science's designated shipping point. Prices do not include, and Buyer shall pay applicable sales tax unless Buyer provides Cardiac Science with a valid tax exemption certificate. Buyer shall pay all freight, handling and insurance charges for shipments of goods. Upon Buyer's receipt, all goods shall be deemed accepted by Buyer unless Cardiac Science's Order Entry Department is contacted at 1-800-991-5465 within one business day of delivery, specifying the defects or discrepancies in the quality or quantity of goods. All services shall be deemed as accepted upon the performance thereof, unless Buyer provides Cardiac Science notice specifying defects or discrepancies in the quality of such services within one business day of delivery of services.
- 3. Training Services.** When training has been purchased Cardiac Science shall contact Buyer within 5 business days to initiate the scheduling of training classes and Buyer agrees that training classes shall begin no later than 30 days after the date that Buyer receives delivery of the AED equipment. Buyer understands that Federal or State law may require training prior to AED equipment use, and Buyer agrees to meet all applicable requirements for training of personnel and operation of AEDs. The addition of students, classes or rescheduling of any class requires the prior approval of Cardiac Science. If Buyer cancels a scheduled training class within 10 business days, Buyer agrees to pay a 100% cancellation fee. Unused training expires 12 months from purchase.
- 4. Customer Obligations.** Buyer shall immediately notify Cardiac Science's Customer Service Dept. at 1-800-991-5465 in the event of the following: (a) if equipment has been used for an emergency or is in need of service; (b) if the AED indicates, in any manner (either visually or by sound), that the unit requires service. Buyer agrees not to defeat, disable or circumvent any protection mechanism related to the AED device. Buyer agrees to use the AED(s) covered under this agreement in accordance with applicable law, the operating instructions and medical direction outlined in Cardiac Science's AED Response Protocol.
- 5. License.** Cardiac Science hereby grants Buyer a revocable, non-exclusive, non-transferable license to use the products solely in accordance with applicable law and the operating instructions. Buyer may not copy, modify, decompile, disassemble or reverse engineer or create derivative works based upon any Cardiac Science product. Except for the rights expressly granted herein, no right, title or ownership interest in any product or service, including any copyright, patent, trademark, or other intellectual property or proprietary right therein, is conveyed to Buyer, expressly or by implication.
- 6. Indemnification.** Cardiac Science Corporation ("CSC") will defend and indemnify any person or entity who purchases, owns, rents, or leases an Automated External Defibrillator ("AED") from CSC or one of its authorized distributors ("Customer") against any claims, damages, liabilities, or actions asserted by any third party (each, a "Claim") arising out of personal injury caused by any AED if and to the extent the Claim is based upon (i) the failure of an AED to function or perform in accordance with its specifications or (ii) defects in design, material, or workmanship of an AED. CUSTOMER MAY NOT TRANSFER OR ASSIGN ITS RIGHTS UNDER THIS POLICY.

Indemnification under this Agreement is not available to Customer: (i) if the AED is used in any manner other than for its intended purpose; (ii) if Customer does not follow the required maintenance procedures; (iii) for Claims arising from the negligence or other malicious or illegal actions of Customer or its personnel; or (iv) for claims involving use of non-Cardiac Science or out-of-date pads or batteries.

Coverage is effective for the period in which CSC is providing service and related support for AED models manufactured and deployed by CSC.

Customer Responsibilities

Indemnification is contingent upon the following:

- AEDs must be used for its intended purpose and in accordance with the instructions set forth in the AED User Manual.
- Customer must comply with the standard maintenance protocols for the AEDs set forth in the AED User Manual.
- Customer must preserve the self-test, rescue, and other data recorded by the AEDs and provide CSC access to such data.

- Customer must (a) give CSC prompt written notice of the Claim, (b) tender defense of the Claim to CSC, (c) cooperate with CSC and assist in the defense of the Claim, and (d) not settle the Claim without the prior written consent of CSC, which will not be unreasonably withheld.

7. Defense of Claims. Cardiac Science Corporation ("CSC") will assume unrestricted authority to defend or settle all claims under this policy. CSC will not be liable to Customer for any defense expenses (including but not limited to fees and disbursements of legal counsel) incurred by Customer subsequent to CSC's assumption of the defense case.

8. LIMITATION OF LIABILITY. TO THE MAXIMUM EXTENT ALLOWABLE UNDER APPLICABLE LAW, (I) CARDIAC SCIENCE SHALL NOT BE LIABLE TO BUYER FOR ANY INDIRECT, INCIDENTAL, SPECIAL OR CONSEQUENTIAL DAMAGES (INCLUDING BUT NOT LIMITED TO LOST OF PROFITS, BUSINESS AND REVENUE) SUSTAINED OR INCURRED IN CONNECTION WITH THE AGREEMENT AND THE PRODUCTS AND SERVICES THAT ARE SUBJECT TO THE AGREEMENT, REGARDLESS OF THE FORM OF ACTION AND WHETHER OR NOT SUCH DAMAGES ARE FORESEEABLE, AND (II) CARDIAC SCIENCE'S TOTAL LIABILITY UNDER THIS AGREEMENT SHALL BE LIMITED TO THE PURCHASE PRICE PAID BY BUYER HEREUNDER. SOME JURISDICTIONS RESTRICT LIMITATIONS OF LIABILITY, SO THE LIMITATIONS IN THIS PARAGRAPH MAY NOT APPLY TO YOU.

Agenda Item No. 2A

Issue: 2018 General Fund Preliminary Budget and Levy

The City is required to submit to the County Auditor a 2018 General Fund Preliminary Budget and Preliminary Property Tax Levy. The resolutions are attached.

These numbers can be adjusted (decreased only) during the budget process.

Announce Date & Time of Budget and Levy Hearing

“The City Council will hold a public hearing regarding the 2018 proposed budget and tax levy on Monday, December 4, 2017 at 6:45 p.m. at the Waite Park City Hall.”

SUGGESTED MOTION #1: Regarding Adopting the Preliminary 2018 General Fund Budget

Councilmember _____ moved to approve the “Resolution Adopting the Preliminary 2018 General Fund Budget”

Councilmember _____ seconded the motion.

ROLL CALL

- Councilmember Vic Schulz _____
- Councilmember Mike Linnquist _____
- Councilmember Charles Schneider _____
- Councilmember Frank Theisen _____
- Mayor Richard Miller _____

Motion (Approved) (Denied)

SUGGESTED MOTION #2: Regarding Adopting the Preliminary 2018 Property Tax Levy

Councilmember _____ moved to approve the “Resolution Adopting the Preliminary 2018 Property Tax Levy”.

Councilmember _____ seconded the motion.

ROLL CALL

- Councilmember Vic Schulz _____
- Councilmember Mike Linnquist _____
- Councilmember Charles Schneider _____
- Councilmember Frank Theisen _____
- Mayor Richard E. Miller _____

Motion (Approved) (Denied)

RESOLUTION NO. 09/18/17-__
CITY OF WAITE PARK

A RESOLUTION ADOPTING THE PRELIMINARY 2018 GENERAL FUND BUDGET

REVENUES:

Property Taxes	\$ 6,176,757
Gravel Tax	95,000
Franchise Fees	100,000
Liquor Licenses	47,100
Other Licenses & Permits	23,000
Grants & Aids	143,395
Charges for Services	175,750
Fines	81,300
Interest	15,000
Other Sources	80,800
Designated Working Capital	<u>400,000</u>
Total Revenues	\$ 7,338,102

EXPENDITURES:

City Council	\$ 33,095
Mayor	15,045
Planning Commission	4,625
Elections	21,925
Administration	667,725
Assessing	28,800
Audit	23,125
Legal	50,000
Planning & Zoning	142,800
Government Buildings	252,075
Library	17,960
Police	2,802,884
Fire	391,617
Inspections	240,100
Emergency Services	26,115
Animal Control	5,820
Engineering	90,000
Streets	1,340,675
Snow Removal	178,350
Traffic Signs & Signals	33,975
Street Lighting	118,150
Brush Collection	15,575
Weed Control	8,625
Tree Trimming	4,050
Waste Collection/Disposal	361,000
Parks	299,780
Splash Pad	48,150
Insurance	48,000
Miscellaneous	<u>68,061</u>
Total Expenditures	\$ 7,338,102

Adopted by the City Council of the City of Waite Park, Minnesota, this 18th day of September, 2017.

Richard E. Miller, Mayor

ATTEST:

Shaunna Johnson, City Administrator-Clerk-Treasurer

Resolution Adopting the Preliminary 2018 General Fund Budget

ACTION ON THIS RESOLUTION:

Motion for adoption:

Seconded by:

Voted in favor of:

Voted against:

Abstained:

Absent:

Resolution _____.

I hereby certify that the foregoing is a true and correct copy of a resolution adopted by the Waite Park City Council at a duly authorized meeting held on 09/18/17.

Shaunna Johnson
City Administrator-Clerk-Treasurer

RESOLUTION NO. 09/18/17-__
CITY OF WAITE PARK

A RESOLUTION ADOPTING THE PRELIMINARY 2018 PROPERTY TAX LEVY

GENERAL FUND LEVY: **\$ 6,176,757**

TAX ABATEMENT LEVY: **206,850**

DEBT SERVICE LEVIES:

2010A G. O. Refunding Bonds	\$ 27,000
2013 G. O. Improvement Bonds	356,000
2013 G. O. Equipment Certificates	54,000
2016B G. O. CIP Bonds	<u>595,410</u>

TOTAL	\$1,032,410	<u>1,032,410</u>
--------------	--------------------	-------------------------

GRAND TOTAL **\$ 7,416,017**

BE IT RESOLVED THAT:

1. The bond and interest hereinabove is the actual amount requested to be spread upon the tax rolls and any increase or decrease is a result of a deficit or surplus in a particular bond fund.
2. The City Council will hold a public hearing regarding the 2018 proposed budget and tax levy on Monday, December 4, 2017 at the Waite Park City Hall beginning at 6:45 PM. If a continuation hearing is necessary, it will be held on Monday, December 11, 2017, at the Waite Park City Hall beginning at 6:30 PM.
3. The City Administrator-Clerk-Treasurer is hereby instructed to transmit a certified copy of this resolution to the Stearns County Auditor.

Adopted by the City Council of the City of Waite Park, Minnesota, this 18th day of September, 2017.

Richard E. Miller, Mayor

ATTEST:

Shaunna Johnson, City Administrator-Clerk-Treasurer

ACTION ON THIS RESOLUTION:

Motion for adoption:
Seconded by:
Voted in favor of:
Voted against:
Abstained:
Absent:
Resolution _____.

I hereby certify that the foregoing is a true and correct copy of a resolution adopted by the Waite Park City Council at a duly authorized meeting held on 09/18/17.

Shaunna Johnson
City Administrator-Clerk-Treasurer

Agenda Item No. 2B

Issue: Approve 2018 Rural Tax Rates

The 9804, 9805 and 9807 rural tax rates are adjusted annually based on the prior year's urban tax rate increase or decrease.

Based on the prior year's urban tax rate percentage increase of .2%, it is recommended that the 9804 and 9805 rural tax rate for 2018 be adjusted from 38.941% in 2017 to 39.018% in 2018.

Based on the prior year's urban tax rate percentage increase of .2%, it is recommended that the 9807 rural tax rate for 2018 be adjusted from 20.018% in 2017 to 20.058% in 2018.

The 2018 rural tax rate for the new tax code 9808 will be 17.782%.

Councilmember _____ moved to approve the 2018 rural tax rates of 39.018% for tax codes 9804 and 9805, 20.058% for tax code 9807 and 17.782% for tax code 9808.

Councilmember _____ seconded the motion.

ROLL CALL

Councilmember Vic Schulz	_____
Councilmember Mike Linnquist	_____
Councilmember Charles Schneider	_____
Councilmember Frank Theisen	_____
Mayor Richard E. Miller	_____

Motion (Approved) (Denied)

Agenda Item No. 3

Issue: Conditional Use Permit – Expansion of St. Cloud Toyota into Former Dunham’s Space – 400 2nd Street South

BACKGROUND

The request has been submitted by John Dockendorf, as trustee of The Jack L. Dockendorf Revocable Trust Agreement and representing St. Cloud Toyota, to allow for expansion of the St. Cloud Toyota business and facilities into the former Dunham’s space located adjacent to their current property. The applicant has permission of the subject property owner to pursue the Conditional Use Permit application to allow for the expansion.

As the property is located in a B-3, 2nd Street South Corridor Commercial District, sale of new and used automobiles is currently considered as a conditional use. However, at the time of initial development of the current St. Cloud Toyota facility, the proposal was considered a “discretionary use”, and was reviewed and approved by both the Planning Commission and City Council with several recommended revisions which were incorporated, as well as a limitation that no more than 40% of the vehicles offered for sale on the premises may be used vehicles. After review and consideration of the request, staff determined that as the use would currently be considered as a conditional use, it would be best to apply the Conditional Use Permit requirement for the project to proceed.

The former Dunham’s space is independently owned and is separate from ownership of the remainder of the multi-tenant property where it is located. As St. Cloud Toyota has noted that they are “maxed out” with the current space, the opportunity to utilize the property to expand their facility and space became attractive to them.

The applicant is proposing to remove the existing grass berm and associated curb between the parcels, as well as install a new grass berm and landscaped area on the eastern portion of the property, to essentially allow the uninhibited movement of vehicles, customers, and staff between the two buildings. No new curbcuts or street access points are planned or being requested. If the project proceeds and as designs are finalized, staff would need to coordinate with the Fire Department to ensure adequate emergency vehicle access around the building and property. The applicant has advised that they would like to limit the possibility for traffic from the adjacent businesses to drive onto the property. From a staff perspective this seems sensible. However, review of the proposal by the City Engineer noted that the City typically likes to encourage cross-easements between such properties. If cross easements are not required, but emergency vehicle access needs to be maintained upon further review, an option that was discussed was the installation of “knock down” bollards, which prevent passage by regular vehicles but can be driven over by an emergency vehicle of sufficient size, such as a fire truck.

The intent is for use of the building for approximately 50% sales and 50% for expansion of detail and service departments. Two overhead doors would be installed on the western side of the property (not facing 2nd Street South). The exterior of the building would be painted to align

with the existing St. Cloud Toyota buildings. The parking lot area would be utilized for additional vehicle display area.

As the owners of St. Cloud Toyota also own Waite Park Auto & Sport, located at 125 Division Street within Waite Park, they are also considering consolidating this business to the proposed expanded St. Cloud Toyota facility. Waite Park Auto & Sport deals primarily in used vehicles. A standalone used dealership is not allowable in the B-3, 2nd Street South Corridor Commercial District, but when incorporated with the larger St. Cloud Toyota facility the arrangement would be allowable, provided that the entirety of the expanded facility maintains the limitation that no more than 40% of vehicles offered for sale are used. At this time the incorporation of Waite Park Auto & Sport to the proposed expanded facilities is undecided. If it were to proceed, staff would anticipate that the existing Waite Park Auto & Sport facility would quickly be utilized for another used car facility, given the strong interest in used car sales in the area and limited locations which allow for them.

Staff would note that the reuse of a “big box” store location such as the subject property can be very challenging. Our community was fortunate in that the former Kmart facility was able to be redeveloped in a successful manner before sitting vacant for a significant amount of time. Currently we have both the Dunham’s property vacant, as well as the former Gander Mountain location one block over. Staff feels that the expansion of St. Cloud Toyota into the Dunham’s facility is an opportunity that would both utilize this significant space for good use, as well as taking a vacant building out of the larger equation. The use of the property by an established business would be beneficial and help ensure long-term stability for the property and area. Staff believes that this use is overall compatible with the intent of the zoning district and with existing neighboring properties.

The Planning Commission reviewed and recommended approval of the request with conditions as proposed at their September 12th, 2017 meeting. No comments from the public were received. Staff has not received any questions or comments regarding the proposal, aside from media interest, as of Thursday, September 14th.

REQUIRED ACTION

The City Council’s action could be any of the following regarding the request.

1. Approval of the Conditional Use Permit as presented.
2. Approval of the Conditional Use Permit with modified or additional conditions.
3. Denial of the Conditional Use Permit, with findings of fact.
4. The City Council may, at its discretion and with the approval of the applicant, table the matter pending further information from the applicant that will help it render a decision. An extension of the 60-day request review period as noted by State Statutes may be required.

STAFF RECOMMENDATION

Staff recommends approval of the Conditional Use Permit to allow for expansion of an existing new and used automobile sales facility in a B-3, 2nd Street South Commercial District with the following conditions:

1. No more than 40% of vehicles offered for sale upon the entirety of the proposed expanded St. Cloud Toyota at any one time shall be vehicles classified as “used”.
2. The building shall be painted to match or be complimentary to the existing St. Cloud Toyota facilities adjacent.
3. Any new permanent signage requires review and approval via sign permit prior to fabrication or installation.
4. Site layout shall adhere to proposed configuration submitted unless specific approval is provided by City of Waite Park. Major modifications may require review by Planning Commission and City Council.
5. Overhead doors may not face 2nd Street South.
6. Building permits are required for interior building modifications, subject to review and determination by Building Official.
7. No additional curbcut or street access onto 2nd Street South is granted with this approval. Any such approval would be at the discretion of MnDOT.

SUGGESTED MOTION

Councilmember _____ moved to recommend to the City Council to approve or deny the Conditional Use Permit, with the following additional conditions: _____

Councilmember _____ seconded the motion.

ROLL CALL

Councilmember Vic Schulz	_____
Councilmember Michael Linquist	_____
Councilmember Charles Schneider	_____
Councilmember Frank Theisen	_____
Mayor Richard E. Miller	_____

Motion (Approved) (Denied)

2005 agenda

Agenda Item No.

Issue: 418 - 2nd Street S. - St. Cloud Toyota Dealership

BACKGROUND:

We have received a proposal from St. Cloud Toyota to develop the property located at the corner of 2nd Street So. and 6th Ave S. This project is located in the 2nd Street South Corridor (PUD). They are proposing to incorporate the existing Centracare building into the new facility. New car dealerships are permitted in this zoning as a discretionary use. The City Council may approve this use after reviewing it on its individual merit and may impose special aesthetic requirements for their use.

The plans that have been submitted have been put together by the architect for Toyota Corporation. Then once the City has approved the concept, Mike Dockendorf of Toyota will be hiring an architect locally to provide a set of construction documents that will be used to build the project.

A minimum 10-foot landscape area is required along all streets on the perimeter of the site. They are providing landscaping in all of the islands in the parking lot. They are showing 18 customer parking spaces in addition to the service customer parking. The exterior of the building consists of plaster and other panels, which are a high-grade metal or other superior product. There are 2 glass doors, which will face to 2nd Street S. These doors are for the new car delivery area and will be of the design, which makes them appear similar to the glass storefront.

The lighting for the site is shown on the site plan. We discussed the need for shielding the fixtures or providing a fixture, which will provide no more than one-half foot-candle at the property line. They have assured us that the fixtures to be used will meet that requirement. The entire parking area and islands on the site will be provided with B-612 curb and gutter design. All landscaped areas will be provided with lawn irrigation system. I have received a copy of the signs that will be installed on the site. This includes identification and directional. The main identification sign is proposed to be 22-foot in height and will be a minimum of 10-foot setback off all property lines.

PLANNING COMMISSION ACTION:

At the October 11, 2005 Planning Commission meeting, this proposal was reviewed and a recommended to the City Council to approve the project as proposed. There were three conditions that the Planning Commission did recommend being included in the final review and approval. They were 1) suggest that the glass overhead doors facing toward 2nd Street S be moved to the east side of the building, 2) maximum of 40% of the vehicles on the site being offered for sale could be used, and 3) a refuse enclosure needed to be shown.

REQUIRED ACTION:

Review the proposed project for compliance with the 2nd Street So Corridor (PUD) requirements and approve the project in concept and general layout.

STAFF RECOMMENDATION:

I have been working with Mike and Jack Dockendorf over the past couple of months. I'm comfortable with the concept proposal that we have received at this time. Once we have received approval on the concept of the project, the finalized plans and specifications will be review in greater detail by the City Engineer, Public Works Superintendent, Fire Chief, and myself for compliance with all applicable codes and ordinances dealing with this project.

Before you are the updated site plan and front elevation of the building. You will note that the 2 glass overhead doors are being replaced with swinging glass doors facing 2nd St. S. There wasn't enough width in that area to have two garage doors. The new site plan also shows a dumpster enclosure to the east side of the building.

SUGGESTED MOTION:

Councilmember _____ moved to **approve or deny** the concept plan for the proposed dealership for St. Cloud Toyota as requested by Mike Dockendorf.

Conditions: _____

Councilmember _____ seconded the motion.

ROLL CALL

Councilmember Dan Butkowski _____
Councilmember Herman Bartz _____
Councilmember Paul Ringsmuth _____
Councilmember Frank Theisen _____
Mayor Carla Schaefer _____

Motion (Approved) (Denied)

1. CONSENT AGENDA (Cont'd.)

- 1.F. Approved "Resolution For Hearing on Proposed Assessment For Windsorgreene Street And Utility Improvements" (RESOLUTION NO. 10/24/05-3)
- 1.G. Approved "Resolution For Hearing On Proposed Assessment For Angus Acres Improvements" (RESOLUTION NO. 10/24/05-4)
- 1.H. Approved Change Order #4 re: 2003 Waite Avenue improvements
- 1.I. Approved 2nd Avenue NE alternative plan construction.

The motion carried unanimously.

2. 418 2nd STREET SOUTH – ST CLOUD TOYOTA DEALERSHIP PROPOSAL

Building Official Barber reported on a proposal by St. Cloud Toyota to locate their car dealership at 418 2nd Street South and the following comments were made:

- the intent is to add to and remodel an existing structure at that address
- the site plan as drafted by the Toyota Corp architects is not the detailed/final plan but a concept plan
- if the concept plan is approved, the "final" plan will be drafted by local architects for detailed review by staff and city engineer (the proposal would not be brought back for Council review)
- the concept plan was reviewed by the Planning Commission that recommended:
 - a.) glass overhead doors proposed to face 2nd Street South should be moved to the East side of the building
 - b.) allow maximum of 40% of on-site used vehicles being offered for sale
 - c.) a refuse enclosure should be shown on the final plan
- possible driveway coordination with Gander Mountain's driveway to the West
- the building would have pre-cast sides with (Toyota style/color) aluminum siding on the front
- that parking provisions meet current requirements
- discussion regarding possibility of 2nd Street South being restriped for six traffic lanes
- possible road right-of-way for right turn lane for Northbound traffic and that traffic counts do not project a turn lane
- lighting fixtures to meet requirements of no more than one-half foot-candle of light at the property line
- parking area and islands will have curb and gutter design with lawn irrigation systems provided to landscaped areas (10' along streets on the site perimeter)
- sign proposal includes identification and directional types with a main 22' high sign and all signs to be setback a minimum of 10' from all property lines

Motion by Member Bartz, second by Member Ringsmuth, to approve the concept plan for the proposed dealership for St. Cloud Toyota as requested subject to meeting the Second Street South corridor criteria, review by staff, alignment of West exit with Gander Mountain's (614 2nd Street south) driveway, that glass overhead doors be located on the East side of the building, a maximum of 40% of on-site used vehicles being offered for sale, and the refuse area be enclosed. The motion carried unanimously.

3.A. CHARTER-SEREN CABLE FRANCHISE MERGER – LEGAL FIRM

City Administrator Johnson reported that Attorney Dege is assisting the city with the proposed Charter-Seren cable franchise merger and recommends the city retain the firm of Miller and Van Eaton to represent area cities together as one effort. The firm specializes in the line of work with merger agreements and their fees are estimated to be \$25,000 and pro-rated to each city with Waite Park's share estimated to be \$3,650. The company would review the proposed agreement to ensure it meets requirements necessary to proceed forward.

Member Ringsmuth has received citizen comments regarding price concerns if the companies merge (thus no competition). City Administrator Johnson recommended citizens contact City Hall and staff would log concerns received. She stated Waite Park is one of few cities nation-wide that have two cable companies located in the same vicinity and if the merger would be accomplished, the city cannot set a cap on possible high prices charged. At this time cities have the ability to refuse approval of the merger proposal if the merger does not meet concerns.



Google

Land Affected

Remove Grass Berm

Bollards

Grass Berm to be Installed

General Location Map - 400 2nd Street S, St. Cloud Toyota Expansion



Agenda Item No. 4

Issue: Conditional Use Permit – Novel Solar Two LLP and Gary M. & Jodi A. Schneider Trust
– Vicinity of CR 138 and I-94

BACKGROUND

The request has been submitted by Novel Solar Two LLP on behalf and with permission of Gary M. & Jodi A. Schneider (property owners) to allow for a 5 MW standalone solar array in an A-1, Agricultural/Rural Residential District. The proposed use would be located on property they own on the eastern side of County Road 138 and north of Interstate 94 (please see attached General Location Map). The subject property is vacant and the property owner's brother lives adjacent to the site on the northwest corner. Site access is provided via 95th Street along CR 138.

Per the A-1, Agricultural/Rural Residential District standards, staff has made the previous determination that standalone solar arrays are considered a conditional use within the district, under the broader classification of "essential services, governmental and public utility buildings and structures".

The proposed solar array is intended to serve as a "community solar garden" as per an Xcel Energy program approved and supported by the State of Minnesota to provide for renewable energy supplies. The intent of such community solar garden is to offer subscription-based solar power options to homes and businesses which are unable to install solar facilities upon their own property. This proposed site would generate 5MW of power and the land would continue to be owned by the current property owners, with a lease to Novel Solar Two LLP for the project duration of 25 years. The intent would be to remove the solar components and all associated equipment at the end of the 25 year period.

The total proposed array is outlined on the attached site plan. The array would consist of 23,400 total solar panels. The racking system and panels are of same essential design as those which were recently approved for use on the smaller Imholte solar project, being of a static (non-moving) design and do not track or follow the sun. They have an average overall height of 9 ½ feet, although some may be up to a maximum of 15' height depending on grade in their location. The proposed layout is subject to engineering and final Xcel program approval and may change slightly prior to construction, but would be subject to review/approval by both City of Waite Park and the Sauk River Watershed due to its proximity to the Sauk River. The applicants have already submitted details regarding wetland determination request to Stearns County staff. City staff would require that all applicable wetland determinations are complete and any conditions complied with prior to issuance of any building permits for the project.

Equipment pads would be located on the western portion of the site and include five concrete slabs, each 16' x 23', and associated electrical power poles and inverter equipment. The site would be enclosed with perimeter fencing for security purposes. An access road would be constructed to allow access to the site and is depicted on the enclosed site plan. A landscaping/screening plan has been agreed to with the resident (property owner's brother) who

lives to the northwest of the site. It is anticipated that site construction activities would commence in the spring of 2018.

The ground area underneath the array is proposed to have vegetation with low maintenance turf or similar seed mix, with pollinator plantings and/or native grasses per the attached landscaping plan. A low-growing moist mix would be planted in the stormwater basin areas. Periodic site maintenance would be utilized throughout the life of the array to control vegetation growth.

As this request includes a public hearing component, the Planning Commission will need to hold the public hearing prior to any action on the request. Staff has not received any questions or comments regarding the proposal as of Friday, September 8th.

Staff would note that we are currently evaluating options to revise/update City ordinances relating to solar and wind facilities. We are seeing more requests than were initially anticipated as there was an earlier understanding that there was, essentially, a limit on how many could locate within the area given the existing electrical infrastructure. Staff would like to ensure that we do not have an inordinate amount of property being dedicated to such uses and that there is some balance maintained for other opportunities within the 25 year timeframe dedicated to these uses. Staff has also determined that, due to the timeframe limitations of solar uses, they would be better classified as an Interim Use Permit which would expire at the end of the established term. To allow time for such review and evaluation and to establish proposed changes, staff may be pursuing establishment of a moratorium on solar and wind energy applications in the near future, for a term of approximately six months.

Given the location of the proposed facility and that it is at the far western edge of City limits and not in what is determined to be a commercial growth area, staff does not oppose the proposed solar facility.

The Planning Commission held the public hearing and reviewed the request at their September 12th, 2017 meeting. Concerns were heard by a neighboring property owner from the opposite side of the road regarding views of the equipment. After discussion the Planning Commission recommended adding a condition regarding submittal of plans for additional screening for the portion of the site immediately adjacent to County Road 138. The Planning Commission recommended approval of the request with the suggested and added conditions.

REQUIRED ACTION

The City Council's action could be any of the following regarding the request.

1. Approval of the Conditional Use Permit as presented.
2. Approval of the Conditional Use Permit with modified or additional conditions.
3. Denial of the Conditional Use Permit, with findings of fact.
4. The City Council may, at its discretion and with the approval of the applicant, table the matter pending further information from the applicant that will help it render a decision. An extension of the 60-day request review period as noted by State Statutes may be required.

STAFF RECOMMENDATION

Staff recommends approval of the Conditional Use Permit to allow a 5 MW solar array in an A-1, Agricultural/Rural Residential District with the following conditions:

1. Landscape plan shall require revisions to screen area of site immediately adjacent to County Road 138 and as depicted in exhibit. Applicant shall coordinate with neighboring adjacent property owner and submit documentation that screening plan is satisfactory to them prior to approval of building permit. Remainder of submitted landscape plan shall be implemented as submitted and reviewed unless otherwise approved by City of Waite Park Planning & Community Development Director. Use of pollinator blend for site is encouraged.
2. Site layout shall adhere to proposed configuration submitted unless specific approval is provided by City of Waite Park. Major modifications may require review by Planning Commission and City Council.
3. All necessary building, land disturbance, and electrical permits shall be obtained prior to project commencement.
4. Approval of Sauk River Watershed District for finalized project configuration shall be submitted at time of building permit application.
5. All approvals of wetland delineations and applicable determinations must be submitted prior to issuance of any building permits.
6. The project shall be decommissioned and the site returned to pre-construction conditions by end of 2044.

SUGGESTED MOTION

Councilmember _____ moved to recommend to the City Council to approve or deny the Conditional Use Permit, with the following additional conditions: _____

Councilmember _____ seconded the motion.

ROLL CALL

- Councilmember Vic Schulz _____
- Councilmember Michael Linquist _____
- Councilmember Charles Schneider _____
- Councilmember Frank Theisen _____
- Mayor Richard E. Miller _____

Motion (Approved) (Denied)

Novel Solar Two LLP

Introduction

Community Solar Gardens are supported by the State of Minnesota as a renewable energy supply. The Xcel Energy program was approved by the State of Minnesota as part of the renewable energy jobs bill in 2013. The purpose of constructing a community solar garden (solar array) will be to generate offsite solar energy that will be connected directly to the electric grid for the on-going benefit of subscribers to the solar garden. As many as 75% of homes and businesses are unable to install solar at their property making off-site solar energy production their only option.

This proposed site will be constructed to produce 5MW AC of electric generation. The electrical energy will be distributed directly to the existing electrical grid for subscribers to the energy produced by the system. The impact to the area is low from a construction, operation, and end of life perspective. Construction and setup are not invasive. Solar energy production is a passive activity, and the system does not alter the underlying nature of the land which can be returned to any other appropriate use. The system will reduce the carbon footprint and greenhouse gas emissions. Subscribers to the community solar garden will save on their electric bills over the 25 year life of the agreement with Xcel Energy, money which can be saved and spent in support of the local economy.

Community solar gardens offer numerous benefits to the community. Subscribers have an opportunity to keep electric dollars in the area to support the local economy. Land owners have a new option that brings value to their property without impacting the underlying nature of the land. Harvesting the sun entails far less risk than other commodities. Land owners and the community have an opportunity to be leaders in renewable energy that sets an example for others to follow, and leaves a positive lasting legacy. Distributed solar generation, energy produced at multiple locations across the grid helps prevent electric line loss and dependence on carbon-based fuel sources. Careful siting standards protect the integrity of the land, increases production which increases local revenues and savings, and ensures positive neighbor relations.

Solar panels and systems have been used in the United States for over forty years and have gained in popularity as the cost of solar energy becomes competitive with traditional fossil fuels, and because of positive environmental benefits. Solar systems are more widely found on the east and west coasts of the United States due to higher electric costs than Minnesota and the Midwest. Solar systems have been found to be good neighboring land uses due to their passive nature, no negative impact on neighbor property values, and benefits to the environment and local economy.

Novel Solar Two LLP

Description

The parcel is owned by the Gary M & Jodi A Schneider Trust

PID# 98.61601.0169

Legal Description: 61.70 A. NW4 LYING E OF CO RD 138 LESS RR LESS 40A TO STATE FOR PIT LESS 10.75A FOR HWY LESS 11.60A & PART SLY OF I94

Parcel Description: Agricultural/Rural Residential

Site Access: Access off 95th St. County Road 138

Equipment

The project will consist of 23,400 ground mounted panels which will feed inverters which ultimately connect to the electric grid at the point of interconnection, engineered to meet industry, state and federal standards.

The primary metering switchgear, grounding equipment and transformers will be placed on five concrete slabs on grade sized 16'x23' on the northwest side of the site for easy access. All non-Xcel Energy equipment, materials, supplies, concrete, etc. will be removed at the end of the useful life of the project.

All equipment must meet Xcel Energy and national standards for safety and interconnection. Program requirements include adequate levels of insurance coverage and a signed interconnection agreement as required by the MN Public Utilities Commission for 25 years with an option for a five year extension, with continual production monitoring.

Site Appearance & Impact

The property is vacant and the property owner's brother lives adjacent to the site on the NW corner and there has been an agreement made with him to provide additional screening to block his view from the array. The attached layout provides the proposed layout, which is subject to final structural engineering. The final layout will continue to meet all City of Waite Park requirements and performance standards.

Novel Solar Two LLP

Landscaping

A landscaping plan has been completed for the project site and a native grass mix will be planted under the arrays, a native pollinator mix will be planted in the open areas and a low growing moist mix will be planted in the permanent stormwater basin.

Hydrology

Three temporary sedimentation basins are proposed for during construction and until final stabilization. The first is in the northwest corner and that will be designed to hold 1.44 acre-feet, the second is in the southeast corner and it will be designed to hold .77 acre-feet, and the third is located in the south central portion of the project and will hold 1.01 acre feet. Additionally, a permanent sedimentation basin will be constructed in the north central area of the site and it will be designed to hold 13,760 cubic feet with permanent erosion control at the outlet.

Construction

Construction activities will begin in spring or early summer of 2018. All necessary equipment and supplies will be delivered within a 2-4 week period at the start of construction. During the start of construction there will only be an average of two semi-trailers per day. Construction is expected to take 4 weeks. Temporary parking and staging will be off-road on the property. Disposal of waste materials will comply with all local, state and federal regulations and best practices.

Potential to Effect the Environment and Public Health

This project is focused on bringing additional green energy to people in Minnesota unable to access solar on their property, and reduce Xcel Energy's and the state's carbon emissions. The proposed solar array is passive and is designed to capture the sun's rays, not reflect them. Solar panels have an equivalent glare factor as a body of water. Research on potential environmental and public health issues will be through the State of Minnesota and the Federal government databases to ensure compliance. The many-decade history of solar panel use has not identified public health or environmental issues.

Novel Solar Two LLP

Decommissioning and Insurance

Within one hundred eighty (180) days of the end of the project useful life, decommissioning will include the removal of all of the solar arrays, cables, electrical components and other ancillary facilities owned by the solar garden.

The Xcel Energy tariffs governing this program and all interconnection as approved by the MN Public Utilities Commission includes interconnection and insurance requirements. Sections 9 & 10 of Xcel Energy's tariff for the Solar*Rewards Community, and Interconnection respectively spell out the requirements. Insurance coverage includes a \$2 million per occurrence policy, and interconnection to the Xcel Energy grid cannot occur until all safety and security items have been engineered, reviewed and approved. State and National electrical codes must be met, inspected and approved prior to interconnection. A signed interconnection agreement with Xcel Energy will be provided prior to construction activities.

Conclusion

We are excited to complete this project in a strong partnership with the Schneider's and the City of Waite Park. We are committed to following best practices and all State, Federal and local rules and regulations to develop a community solar garden providing the many benefits to the local community.

Schneider Solar CUP - Additional Landscape Area in



September 14, 2017

- Parcels
- Municipal Boundary

General Location Map - Schneider Solar Array, S





1 Site Plan
1" = 150'

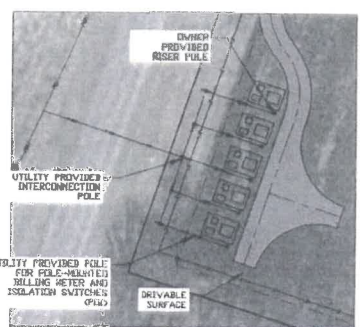

2 XCEL Utility Pole Layout
1" = 40'

LEGEND

- PROPERTY LINE
- ▬ SOLAR RACK (240)
- - - SITE SETBACKS
- PERIMETER FENCE
- EQUIPMENT PAD (50)
- SITE ROAD
- UTILITY POLE
- HV FEEDER LINE
- OVERHEAD UTILITY LINE
- INVERTERS (80)

NOTES

1. THIS DRAWING IS FOR ILLUSTRATIVE PURPOSES ONLY.
 2. RESULTS OF EASEMENT REPORTS, UNDERGROUND UTILITIES, HYDROLOGY AND GEOTECH REPORTS MAY AFFECT THE FINAL PV-ARRAY LAYOUT.
 3. ACCESS ROADS AND DRIVEWAYS WILL BE PROVIDED FOR XCEL EQUIPMENT ACCESS.
 4. 24/7 UNLIMITED ACCESS FOR XCEL SERVICE.
 5. THE AC DISCONNECT SHALL BE READILY ACCESSIBLE AND TYPICALLY LOCATED WITHIN 10' OF THE MAIN SERVICE METER.
 6. THE SOLAR ARRAY AND INTERCONNECTION EQUIPMENT ARE LOCATED OUTSIDE OF FEMA ZONE AE FLOODWAY AND SPECIAL FLOOD HAZARD AREA (SFHA). THE ZONE AE SHALL BE SUBJECT TO REVISION BY THE 15 ANNUAL CHANCE FLOOD WHEAT BASE FLOODWAYS AND IS SHOWN.
- PV SYSTEM:
AZIMUTH: 180°
TILT ANGLE: 30°
PIVOT (ROW-TO-ROW SPACING): 30'
PV MODULES: MONO SOLAR, 325W, 72 CELL, POLY MODULES PER STRING: 18
- RACK CONFIGURATION:
GROUND MOUNT, AP ALTERNATIVES
EACH RACK CONSISTS OF 9 ROWS OF 2 MODULES IN PORTRAIT
- INVERTER INFORMATION:
ONLY POWER SYSTEMS PM SPLIT BOND (20)
STRINGS PER INVERTER: 12 STRINGS
DC/AC RATIO: 1.404

NOTES

TOTAL HV XFMRS ON SITE = 1000KVA (5)
HV FEEDER LENGTH (DISTANCE FROM POI TO PCC) = 150'

PROJECT NAME	SCHNEIDER SOLAR PROJECT
GARDEN OPERATOR NAME	NOVEL SOLAR TWO, LLP
APPLICATION MANAGER - PHONE	(507) 261-8499
APPLICATION MANAGER - EMAIL	MENA.KAEHLER@NOVELENERGY.BIZ
SRC #	SRC0XXXXX
SRC ADDRESS	9137 COUNTY RD 138 CSG A ST CLOUD, MN 56301
SRC CAPACITY DC KW	1404
SRC CAPACITY AC KW	1000
SRC PV WATTS LOCATION	XXXXXXXXXX
ARRAY TILT	30°
ARRAY AZIMUTH	180° (S)
ARRAY-TRACKER TYPE	FIXED AXIS
ARRAY MOUNT LOCATION	45.5260°, -94.2979°
WILL SELL REC'S	YES
SRC EST COMPLETION DATE	
SRC KWH/YEAR (PVWATTS)	X,XXX,XXX

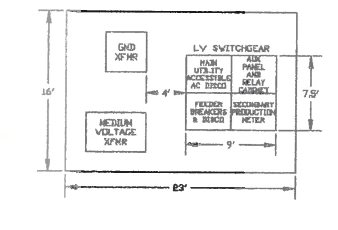

3 Equipment Pad Plan
NTS

VICINITY MAP



SYSTEM SIZE (AC): 1.00MW
SYSTEM SIZE (DC): 1.40MW

Westwood
Westwood Professional Services, Inc.
www.westwoodps.com

Drawn	PCB
Checked	PCB
Design	PCB
Project Manager	
Author	
Date	
Revision	
1. 08/23/17 Preliminary Layout	
2. 08/23/17 K. Orelowitz	

Novel Energy Solutions
Novel Solar Two, LLP
475 Cleveland Ave. N., Suite 222
St. Paul, MN 55104

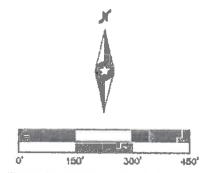

Schneider Solar Project
Stearns County, Minnesota

Preliminary
Not Issued For Construction

Date: 8/23/17
Sheet 1 of 3

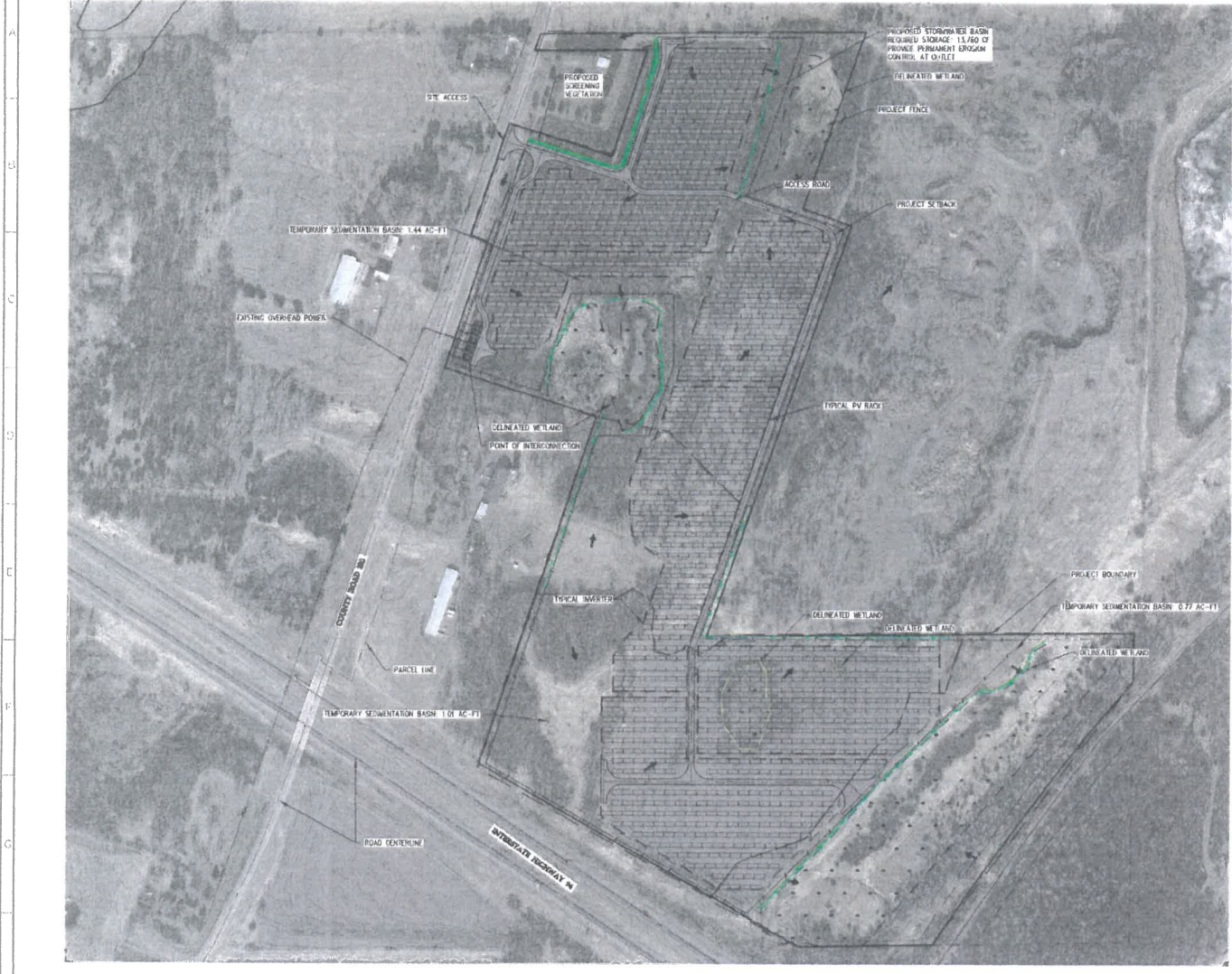

LEGEND

	SOLAR PV RACK
	CORNER BOX
	15' WIDE SITE ACCESS ROAD
	LANDSCAPE BARRIER
	POWER OVERHEAD
	PROJECT SITE SECURITY FENCE
	PROPERTY LINE
	SALT FENCE
	FIBER ROLL
	FIELD DELIMITED WETLANDS
	DRAINAGE AREA BOUNDARY
	FLOW DIRECTION ARROWS
	TOP OF PERMANENT BASIN

Westwood
 Professional Services, Inc.
 Phone: (862) 337-8100 7066 Ardenway Dr. No
 Fax: (862) 337-8832 c. west@westwood.com
 Web: www.westwood.com
 Westwood Professional Services, Inc.

Designed:	USD	
Checked:	JRM	
Drawn:	USD	
Revised Drawing by/Date:		
Revisions:		
#	DATE	DESCRIPTION
1	08/17/2017	ISSUE FOR PERMIT
2	08/22/17	AS B SUBMITTED

Prepared for:
Novel Energy Solutions
 Novel Solar Two, LLP
 475 Cleveland Ave. N., Suite 222
 St. Paul, MN 55104

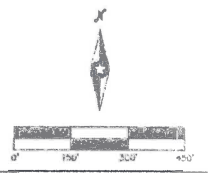

Schneider Solar Project
 Stearns County, Minnesota

Site Hydrology
 Preliminary
 Not Issued For Construction
 Date: 8/17/2017
 Sheet: C.103
 0013133 00 Site Hydrology

1 Site Plan
 1" = 150'

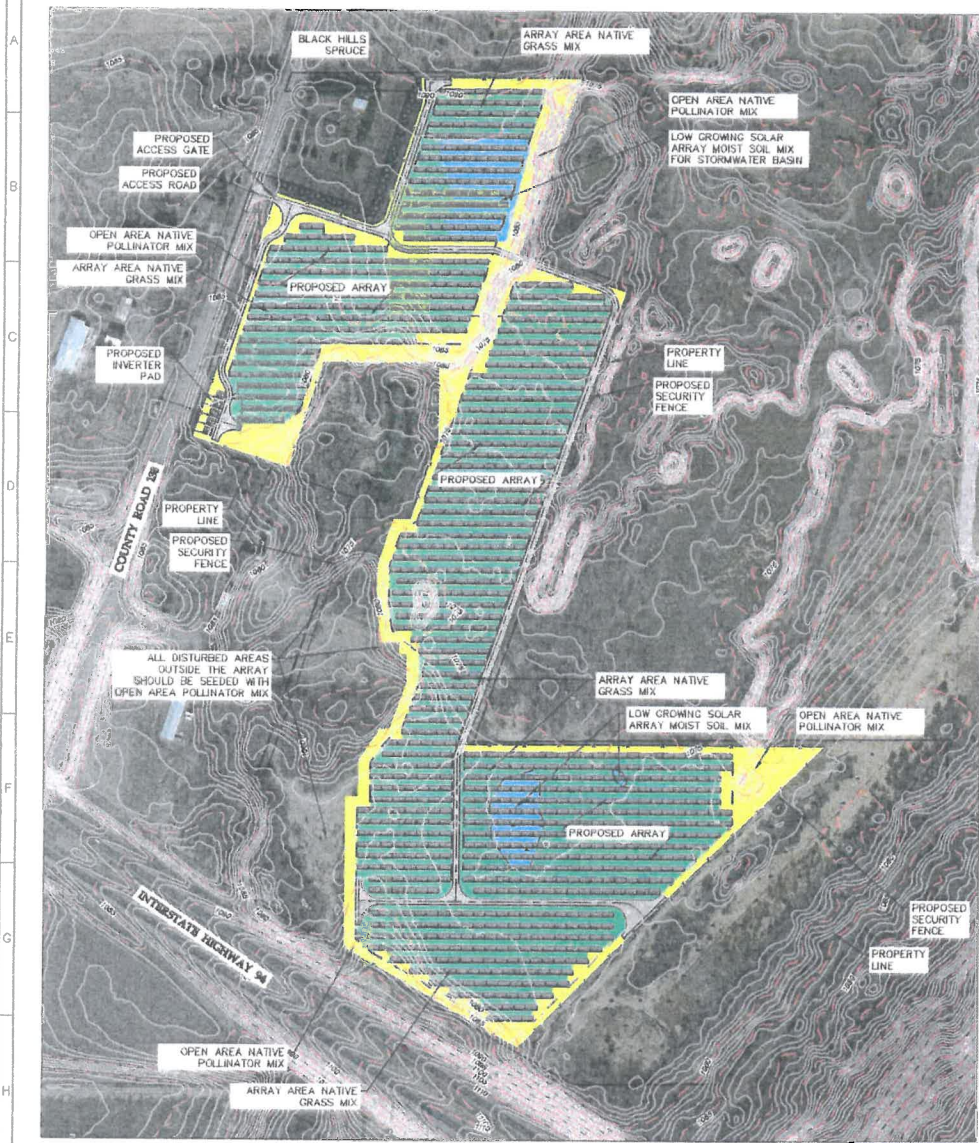

Buffer Planting Schedule

KEY	QTY.	COMMON/BOTANICAL NAME	SIZE	SPACING	O.C.	NATURE HEIGHT
5	100	Black Hills Spruce / Picea canadensis	4' Ht. 80	30'-20'	O.C.	30-47'

NOTE: QUANTITIES ON PLAN SUPERSEDE LIST QUANTITIES IN THE EVENT OF A DISCREPANCY.

Buffer Planting Materials



Seeding Legend

- DENOTES PROPOSED SECURITY FENCE
- YELLOW OPEN AREA POLLINATOR NATIVE MIX (7.1 AC)
- GREEN ARRAY AREA NATIVE GRASS MIX (24.3 AC)
- BLUE LOW GROWING SOLAR ARRAY MOIST SOIL NATIVE MIX (1.8 AC)

Professional Services, Inc.
 10000 Hennepin Avenue, Suite 100
 Minneapolis, MN 55424
 (612) 835-1100
 www.westwoodps.com

Prepared	MM
Checked	MM
Drawn	MM
Revised Drawing by/when	
Revisions	
1	
2	
3	
4	
5	
6	
7	
8	

Prepared by:

Novel Energy Solutions

Novel Solar Team, LLP
 475 Cleveland Ave. N., Suite 222
 St. Paul, MN 55104

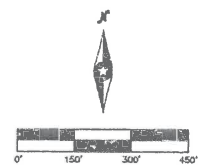

Schneider Solar Project
 Stearns County, Minnesota

Preliminary Landscape Plan

Preliminary Not Issued For Construction

Date: 8/24/17
 Sheet: C-300

Planting Notes

- CONTRACTOR SHALL CONTACT COPPER "ONE CALL" (800-454-0002 or 800-262-1164) TO VERIFY LOCATIONS OF ALL UNDERGROUND UTILITIES PRIOR TO INSTALLATION OF ANY PLANTS OR LANDSCAPE MATERIAL.
- ACTUAL LOCATION OF PLANT MATERIAL IS SUBJECT TO FIELD AND SITE CONDITIONS.
- NO PLANTING WILL BE INSTALLED UNTIL ALL GRADING AND CONSTRUCTION HAS BEEN COMPLETED IN THE IMMEDIATE AREA.
- ALL SUBSTITUTIONS MUST BE APPROVED BY THE LANDSCAPE ARCHITECT PRIOR TO SUBMISSION OF ANY BID AND/OR ORDER BY THE LANDSCAPE CONTRACTOR.
- CONTRACTOR SHALL PROVIDE ONE YEAR GUARANTEE OF ALL PLANT MATERIALS. THE GUARANTEE BEGINS ON THE DATE OF THE LANDSCAPE ARCHITECT'S OR OWNER'S WRITTEN ACCEPTANCE OF THE INITIAL PLANTING. REPLACEMENT PLANT MATERIAL SHALL HAVE A ONE YEAR GUARANTEE COMMENCING UPON PLANTING.
- ALL PLANTS TO BE SPECIMEN GRADE, MINNESOTA-GROWN AND, OR HARDY. SPECIMEN GRADE SHALL ADHERE TO, BUT IS NOT LIMITED BY, THE FOLLOWING STANDARDS:
 - ALL PLANTS SHALL BE FREE FROM DISEASE, PESTS, WOUNDS, SCARS, ETC.
 - ALL PLANTS SHALL BE FREE FROM NOTICEABLE CUPS, HOLES, OR DEFORMITIES.
 - ALL PLANTS SHALL BE FREE FROM BRUSH OR DEAD BRANCHES.
 - ALL PLANTS SHALL HAVE HEAVY, HEALTHY BRANCHING AND LEAFING.
 - CONIFEROUS TREES SHALL HAVE AN ESTABLISHED MAIN LEADER AND A HEIGHT TO DBH RATIO OF NO LESS THAN 5:1.
- PLANTS TO MEET AMERICAN STANDARD FOR NURSERY STOCK (ANSI Z60.1-2004 OR MOST CURRENT VERSION) REQUIREMENTS FOR SIZE AND TYPE SPECIFIED.
- PLANTS TO BE INSTALLED AS PER MHA & ANSI STANDARD PLANTING PRACTICES.
- PLANTS SHALL BE IMMEDIATELY PLANTED UPON ARRIVAL AT SITE. PROPERLY HEEL-IN MATERIALS IF NECESSARY; TEMPORARY DAILY.
- PRIOR TO PLANTING, FIELD VERIFY THAT THE ROOT COLLAR/ROOT FLAIR IS LOCATED AT THE TOP OF THE BALLED & BURLAP TREE. IF THIS IS NOT THE CASE, SOIL SHALL BE REMOVED DOWN TO THE ROOT COLLAR/ROOT FLAIR. WHEN THE BALLED & BURLAP TREE IS PLANTED, THE ROOT COLLAR/ROOT FLAIR SHALL BE EVEN OR SLIGHTLY ABOVE FINISHED GRADE.
- REMOVE POT ON POTTED PLANTS. SPLIT AND BREAK APART PEAT POTS.
- PRUNE PLANTS AS NECESSARY - PER STANDARD NURSERY PRACTICE AND TO CORRECT POOR BRANCHING OF EXISTING AND PROPOSED TREES.
- THE NEED FOR SOIL AMENDMENTS SHALL BE DETERMINED UPON SITE SOIL CONDITIONS PRIOR TO PLANTING. LANDSCAPE CONTRACTOR SHALL NOTIFY LANDSCAPE ARCHITECT FOR THE NEED OF ANY SOIL AMENDMENTS.
- BACKFILL SOIL AND TOPSOIL TO ADHERE TO MHD/DOT STANDARD SPECIFICATION 3677 (COMMON TOPSOIL BOUND) AND TO EXISTING TOP SOIL FROM SITE FREE OF ROOTS, ROCKS LARGER THAN ONE INCH, SUBSOL DEBRIS, AND LARGE WEDDS UNLESS SPECIFIED OTHERWISE. MINIMUM 12" DEPTH TOPSOIL FOR TREE, SHRUBS, AND PERENNIALS.
- PROMOTE MULCH FOR ALL TREE AND SHRUB PLANTINGS PER DETAIL. MULCH TO BE SHREDDED HARDWOOD AND FREE OF DESTRUCTIVE MATERIAL, HEALTHY 3" DIAMETER RING AROUND ALL TREES AND SHRUBS TO A DEPTH OF 4". KEEP MULCH OFF TRUNK.
- CONTRACTOR SHALL PROVIDE NECESSARY WATERING OF PLANT MATERIALS UNTIL THE PLANT IS FULLY ESTABLISHED OR IRRIGATION SYSTEM IS OPERATIONAL. OWNER WILL NOT PROVIDE WATER FOR CONTRACTOR.
- REPAIR, REPLACE, OR PROMOTE SOIL/SEED AS REQUIRED FOR ANY ROADWAY BOLLERVAID AREAS ADJACENT TO THE SITE DISTURBED DURING CONSTRUCTION.
- REPAIR ALL DAMAGE TO PROPERTY FROM PLANTING OPERATIONS AT NO COST TO OWNER.

Planting Details

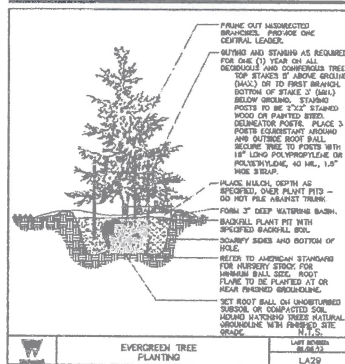

Open Area Pollinator Mix

GRASS SPECIES	% OF MIX	PLS. (LBS./ACRE)
BOUTELOUA CURTIPENDULA	25.00	1.25
BOUTELOUA GRACILIS	10.00	0.70
BROMUS KALKEI	2.50	0.18
ELYNUS VILLOSIUS	10.00	0.70
HECZELIA MACRANTHA	1.00	0.11
SPHONCHYLUM SCOPARIUM	20.00	1.40
SPHONCHYLUS HETEROLEPIS	6.00	0.42
ORCHARD GRASS	1.00	0.07
YARROW	0.50	0.04
AGASTACHE FIBROSUM	0.75	0.05
ALUMINUM STELLARIUM	0.50	0.04
ASPERULA INCURVATA	1.00	0.07
AROLEPAS STYRACIS	1.00	0.07
ARTEMISIA TRUCIDATA	1.00	0.07
ASTER DODECANTHUS	1.00	0.07
ASTER LATERIFLORUS	1.00	0.07
ASTER NOVIFOLIUS	1.00	0.07
ASTRALAGUS CANADENSIS	1.00	0.07
DALEA CAROLINENSIS	2.00	0.14
DALEA PURPUREA	1.00	0.07
DESMODIUM CANADENSE	1.00	0.07
LYTHRIS PUCHOTADZYA	1.00	0.07
MONARDA PESTALOTIA	0.75	0.05
PHENISTEMON GRACILIS	0.50	0.04
POTENTILLA ANSATTA	1.00	0.07
PYRAMIDOPSIS VIRGINIANUM	0.75	0.05
RATIBIDA PINNATA	0.75	0.05
RUBROCOCA VITATA	1.50	0.11
SOLIDAGO RIGIDA	1.75	0.12
TRICHOANTHA BRACKETATA	0.50	0.04
VERBENA HASTATA	1.00	0.07
VERBENA STRICTA	1.00	0.07
ZIZA AUREA	1.00	0.07

Low Growing Solar Array Moist Soils Mix

GRAMINOID SPECIES	% OF MIX	PLS. (LBS./ACRE)
CHAMAECRISTIS CHAMAECRISTIS	1.25	0.08
GLYCERHA STRIATA	3.00	0.19
LEERSIA ORYZOIDES	2.84	0.18
POA PALUSTRIS	18.33	0.42
LEGUME SPECIES	% OF MIX	PLS. (LBS./ACRE)
ASTRALAGUS CANADENSIS	0.37	0.02
DALEA CANADA	1.36	0.04
DALEA MEX. VETIC.	0.17	0.01
DALEA SPINATA	1.82	0.07
DALEA VILLOSIDES	3.67	0.11
DALEA VILLOSIDES	36.68	0.68
DALEA MEX. VETIC.	0.67	0.01
DALEA SPINATA	0.17	0.01
DALEA VILLOSIDES	0.34	0.02
DALEA VILLOSIDES	0.73	0.04
DALEA VILLOSIDES	0.23	0.01
DALEA VILLOSIDES	2.86	0.02
DALEA VILLOSIDES	0.07	0.01
DALEA VILLOSIDES	0.08	0.01
DALEA VILLOSIDES	0.48	0.01
DALEA VILLOSIDES	1.43	0.10
DALEA VILLOSIDES	1.45	0.05
DALEA VILLOSIDES	0.48	0.03
DALEA VILLOSIDES	0.58	0.03
DALEA VILLOSIDES	4.58	0.17
DALEA VILLOSIDES	0.82	0.25

Array Area Native Grass Mix

GRASS SPECIES	% OF MIX	PLS. (LBS./ACRE)
BOUTELOUA CURTIPENDULA	35.00	3.48
BOUTELOUA GRACILIS	35.00	2.10
CAREX BOWLEII	1.00	0.06
CAREX PACIFICA	1.00	0.00
CAREX VULPINOIDEA	1.00	0.00
HECZELIA MACRANTHA	1.00	0.00
SPHONCHYLUS HETEROLEPIS	3.00	0.18
WHEAT	10.00	0.00

Seeding Notes

- SEEDING TO BE COMPLETED USING A DRILL SEED METHOD WHERE FEASIBLE. WHERE DRILL SEEDING IS NOT FEASIBLE THE APPLICATION OF SEED VIA ALTERNATE METHODS INCLUDING BUT NOT LIMITED TO, BROADCAST OR HYDROSEEDING.
- BROADCAST SEEDING SHALL BE COMPLETED IF AMBIENT SOIL TEMPERATURE IS CONSISTENTLY 60 DEGREES F OR LOWER.
- IF NOT FROST SEEDING, DRILLING SHOULD OCCUR BETWEEN APRIL 1ST AND JUNE 1ST.
- IF THE CONTRACTOR SHALL NOT TILL OR FERTILIZE THE FIELDS, IF THE GROUND NEEDS TO BE TILLED, CONTRACTOR SHALL USE A VERTICAL FLOW.

- * NOTES
- * SPECIAL SEED MIX DESIGNED BY MINNESOTA NATIVE LANDSCAPES
- * SEE IF CHANGES ARE NECESSARY FOR SPECIFIC LOCATION
- * MINNESOTA NATIVE LANDSCAPES
- * 8740 77TH STREET NE
- * OTSEGO, MN 55301

Westwood

Westwood Professional Services, Inc.
 8740 77th Street NE
 Otsego, MN 55301
 Phone: (763) 437-1111
 Fax: (763) 437-1112
 Email: info@westwoodmn.com

Project No.	1000
Client	Novel Energy Solutions
Address	8740 77th Street NE, Otsego, MN 55301
Proposed For	

Novel Energy Solutions
 Novel Solar Two, LLP
 675 Cleveland Ave. N., Suite 222
 St. Paul, MN 55108

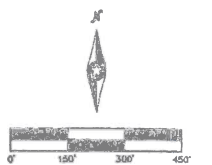

Schneider Solar Project
 Stearns County, Minnesota

Preliminary Landscape Plan

Preliminary Not Issued For Construction

Date: 8/24/17
 Sheet: C301

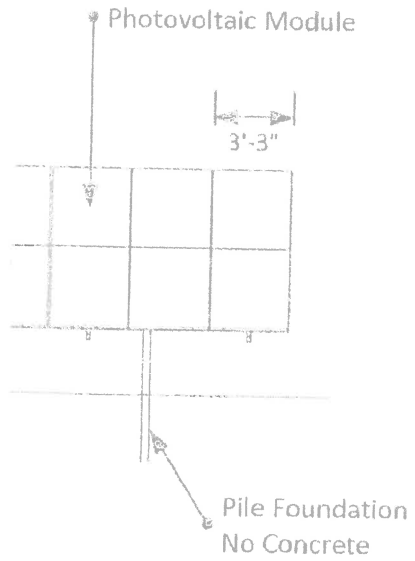

Array Detail Front
Scale: 1/8" = 1'

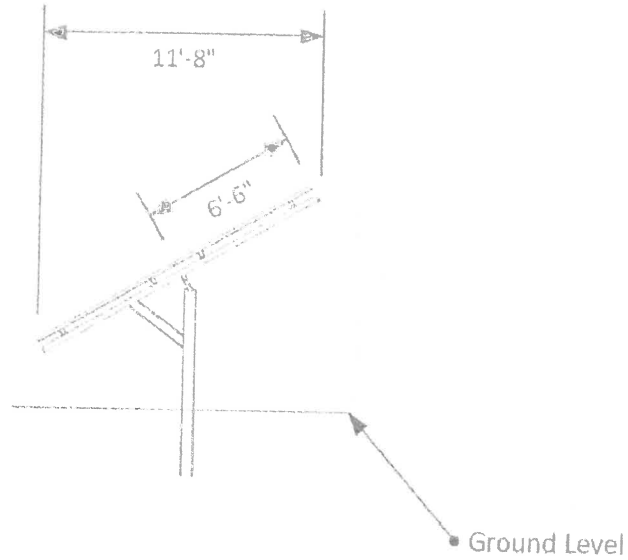

Array Detail Side
Scale: 1/8" = 1'

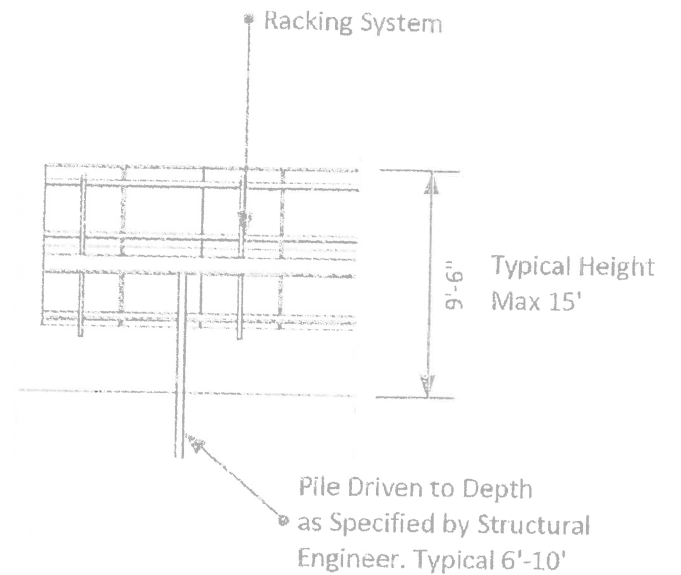

Array Detail Rear
Scale: 1/8" = 1'

Agenda Item No. 5

Issue: Public Nuisance Abatement – Property at 212 5th Avenue North, Waite Park, Minnesota

BACKGROUND: Pamela M. Olson is the owner of property located at 212 5th Avenue North, Waite Park, Minnesota, legally described as follows:

Lots 17 and 18, Block 6, in the Townsite, now City of Waite Park, according to the plat and survey thereof on file and of record in the office of the County Recorder in and for Stearns County, Minnesota.

Jon Noerenberg, the Planning and Community Development Director, acting as the Building/Code Enforcement Officer, contacted Pamela Olson several times beginning April 15, 2015, in which he requested Ms. Olson remove various rubbish items (junk vehicles, items on hoist, tires, miscellaneous parts and other items) on the above described property determined by Mr. Noerenberg to be a public nuisance as defined in City Ordinance 90. See attached pictures of the problem items and storage. The most recent contact by Jon Noerenberg was by letter dated August 18, 2017, delivered to Ms. Olson via personal service by posting on the property on August 18, 2017, in which he requested Ms. Olson clean up the property by August 23, 2017. As of August 23, 2017, the nuisance conditions still exist on the above described property. Jon Noerenberg is requesting an abatement order and authorization for the City of Waite Park to clean up the property, remove and/or abate the nuisance conditions on the property and assess the costs incurred by the City relating to the clean-up, removal and/or abatement of the nuisance conditions and the costs of the enforcement action against the above described property located at 212 5th Avenue North, Waite Park, Minnesota. Ms. Olson was served with notice of the abatement hearing scheduled on September 18, 2017, via personal service by posting on the above described property on September 6, 2017.

REQUIRED ACTION: Approve Or Deny a resolution to abate nuisance and recover the costs by assessing them against the above described property located at 212 5th Avenue North, Waite Park, Minnesota, owned by Pamela M. Olson, in the same manner as taxes and special assessments.

RECOMMENDED ACTION: The decision is up to the Council.

SUGGESTED MOTION: Council Member _____ moved to approve OR deny the resolution to abate nuisance and assess costs against the above described property located at 212 5th Avenue North, Waite Park, Minnesota, owned by Pamela M. Olson, in the same manner as taxes and special assessments.

Council Member _____ seconded the motion.

ROLL CALL

Council member Charles Schneider _____
Council member Vic Schulz _____
Council member Michael Linqvist _____
Council member Frank Theisen _____
Mayor Richard E. Miller _____

Motion (Approved) (Denied)

RESOLUTION NO. _____
CITY OF WAITE PARK

A RESOLUTION TO ABATE NUISANCE AND ASSESS COSTS

WHEREAS, the City Council has heard the report of Jon Noerenberg, the Planning and Community Development Director acting as the Building/Code Enforcement Officer, regarding nuisance conditions on the property located at 212 5th Avenue North in Waite Park, Minnesota, legally described as follows:

Lots 17 and 18, Block 6, in the Townsite, now City of Waite Park, according to the plat and survey thereof on file and of record in the office of the County Recorder in and for Stearns County, Minnesota;

and

WHEREAS, the City Council has conducted a duly noticed public hearing on the abatement as hereinafter defined at which the views of all interested parties were heard; and

NOW, THEREFORE, BE IT RESOLVED by the City Council of the City of Waite Park, Stearns County, Minnesota, as follows:

1. Findings.

a) The owner of record of the above described property is Pamela M. Olson of Waite Park, Minnesota.

b) Jon Noerenberg has contacted Pamela M. Olson several times beginning April 15, 2015, via certified mail or personal service, with the most recent letter on August 18, 2017, via personal service by posting on the property, requesting Pamela Olson remove various rubbish items (junk vehicles, items on hoist, tires, miscellaneous parts and other items) located on the above described property determined by Jon Noerenberg to be a public nuisance as defined in City Ordinance 90.

c) Mr. Noerenberg's letter of August 18, 2017, requested Ms. Olson remove the nuisance conditions including a newly created fenced-in area and any attachment to neighboring fence by August 23, 2017. The letter included pictures of the problem items and storage.

d) The August 18, 2017, letter also included notice to Ms. Olson that if the property is not cleaned up pursuant to the terms of the Order, the City will pursue an abatement proceeding by which the City will undertake the abatement and recover the costs by assessing them against her property in the same manner as taxes.

e) The conditions present on the above described property constitute a public nuisance as defined in Ordinance 90 of the City of Waite Park's Code of Ordinances.

f) As of August 23, 2017, the nuisance conditions still exist on the above described property.

g) Due to continued nuisance issues and non-compliance with multiple correction orders issued by City staff, the City has scheduled an abatement hearing. Pamela M. Olson was served with notice of the abatement hearing scheduled for September 18, 2017, at 6:30 p.m. at the Waite Park City Hall, 19-13th Avenue North, Waite Park, Minnesota, via personal service by posting on the above described property on September 6, 2017.

September 18, 2017

2. Abatement.

a) In accordance with Ordinance 90 of the City of Waite Park's Code of Ordinances, a public nuisance exists on the above described property.

b) The City of Waite Park is authorized to clean up, remove and/or abate the nuisance conditions on the above described property at the expense of the City of Waite Park.

c) In accordance with Ordinance 90, Section 90.14, Subd. 5, any personal property removed from the premises during the abatement proceeding shall be disposed of in accordance with the provisions of Ordinance 28 of the City of Waite Park's Code of Ordinances. Motor vehicles shall be disposed of in accordance with the provisions of Minnesota Statutes Chapter 168B.

d) The costs incurred by the City of Waite Park relating to the clean-up, removal and/or abatement of the nuisance conditions and the costs of the enforcement action shall be assessed against the above described real property in the same manner as taxes and special assessments are certified and collected. Costs of enforcement shall include administrative costs, including costs of service and posting.

Adopted by the City Council this ____ day of September, 2017.

Shaunna Johnson
City Administrator

Richard E. Miller
Mayor

ACTION ON THIS RESOLUTION:

Motion for adoption:

Seconded by:

Voted in favor of:

Voted Against:

Abstained:

Absent:

Resolution adopted.

I hereby certify that the foregoing is a true and correct copy of a resolution adopted by the Waite Park City Council at a duly authorized meeting held on September ____, 2017.

Shaunna Johnson
City Administrator

September 18, 2017



September 6 2017

Pamela Olson
212 5th Ave North
Waite Park, MN 56387

****PERSONAL SERVICE VIA WAITE PARK POLICE OFFICER****

Re: Notice of Abatement Hearing for Continued Nuisance Violations

Ms. Olson or Current Resident,

This letter serves as notice that the City of Waite Park has scheduled an abatement hearing for your property at 212 5th Ave North, due to continued nuisance issues and non-compliance with multiple correction orders issued by City staff.

As per City Ordinance Section 90.14, Subdivision 2, I have scheduled a hearing with the City Council regarding these issues and am requesting and recommending an abatement order, by which the City will undertake the abatement and recover the costs by assessing them to the property, in the same manner as taxes and special assessments. Costs may also include any and all administrative costs, including costs of service and postings.

You have the right to be heard at the abatement hearing if you choose. The abatement hearing will take place at the following:

Regular City Council Meeting
Waite Park City Hall – 19 13th Ave N, Waite Park, MN 56387
Monday, September 18th
Starting at 6:30PM

You may contact me at (320) 656-8936 or jon.noerenberg@ci.waitepark.mn.us with any questions.

Sincerely,

Jon Noerenberg
Planning & Community Development Director



August 18, 2017

Pamela Olson
212 5th Ave North
Waite Park, MN 56387

****PERSONAL SERVICE VIA WAITE PARK POLICE OFFICER****

Re: Rubbish and Parts in Yard – 212 5th Ave North – FINAL WARNING AND ABATEMENT

Ms. Olson or Current Resident,

This letter is in regards to the various rubbish items (junk vehicles, items on hoist, tires, misc. parts and other items), in the rear yard property at 212 5th Avenue North. Waite Park Ordinance Section 90 prohibits keeping and storing such items unenclosed as they constitute a nuisance by their appearance and as likely attraction for vermin. Section 52.14 prohibits parking or storing of motor vehicles in any yard area other than driveways. Section 90.3 prohibits exterior storage of machinery, motor vehicle component parts, and other junk & debris.

Over the past year, you have been storing an increasing amount of junk, particularly tires in a newly-created fenced in area within the yard. This is unacceptable as it is blight upon the area and neighbors, and is likely to attract vermin. Pictures of these problem items and storage is attached. It is my determination that every item being stored outside and within the fenced in area is rubbish and nuisance per City Ordinance and must be removed.

As per Ordinance Section 90.14 (“Enforcement”), this letter shall serve as notice that the following must be completed by **August 23, 2017**:

- * Remove newly-created fenced in area and any attachment to neighboring fence. Alternately, a building permit may be obtained if you wish to keep the fence in place, but it may not be attached to adjacent fence.
- * Remove all items within current fenced-in area from property. Items you wish to keep must be kept inside garage or home. This includes but is not limited to tires, drums/buckets and all contents, and all other debris and materials.
- * Remove every item located adjacent to garage. Relocate those items you wish to keep inside garage or home.
- * Remove any non-operable or unlicensed vehicles from the property.
- * No more than four (4) licensed and operable vehicles may be located at the home. Submit details as to which vehicles you will be keeping at the property.



The issues of ongoing violations with your property have been discussed previously by the City Council. If your property is not cleaned up per the terms of this order and to my satisfaction the City will pursue abatement proceedings by which the property will be cleaned up and costs billed to you on your taxes by legal order.

You may contact me at (320) 656-8936 or jon.noerenberg@ci.waitepark.mn.us with any questions.

Sincerely,

Jon Noerenberg
Planning & Community Development Director



April 8, 2016

Pamela Olson
212 5th Ave North
Waite Park, MN 56387

**** CERTIFIED MAIL ****

Re: Rubbish and Parts in Yard – 212 5th Ave North

Dear Ms. Olson or Current Resident,

This letter is in regards to the various rubbish items (junk vehicles, engine on hoist, tires, misc. parts and other items), in the rear yard property at 212 5th Avenue North. Waite Park Ordinance Section 90 prohibits keeping and storing such items unenclosed as they constitute a nuisance by their appearance. Section 52.14 prohibits parking or storing of motor vehicles in any yard area other than driveways. Section 90.3 prohibits exterior storage of machinery, motor vehicle component parts, and other junk & debris.

The last notice, served via Waite Park Police Department and dated October 20, 2015, directed cleanup of all items. A follow-up inspection at the time noted that while vehicles were removed per order, the rubbish and parts have were relocated to a newly-constructed fenced-in area.

However, in the time since many more vehicles are now located on the property again, as well as miscellaneous junk debris.

As per Ordinance Section 90.14 (“Enforcement”), this letter shall serve as notice that the following must be completed by April 25, 2016:

- * Remove newly-created fenced in area and any attachment to neighboring fence. Alternately, a building permit may be obtained if you wish to keep the fence in place, but it may not be attached to adjacent fence.
- * Remove all items within current fenced-in area from property. Items you wish to keep must be kept inside garage or home.
- * Remove all debris located adjacent to garage. Relocate those items you wish to keep inside garage or home.
- * Remove any non-operable or unlicensed vehicles from the property.
- * No more than four (4) licensed and operable vehicles may be located at the home. Submit details as to which vehicles you will be keeping at the property.



If these actions are not completed I will be pursuing administrative penalties (fines) against you as the property owner. These fines increase in time when they are not paid and may also culminate in a criminal offense. If the property is not maintained and additional code violations are found the fees are doubled for every subsequent violation. These fees can add up quickly.

If you would prefer to work out a plan to bring your property into compliance rather than deal with ongoing letters and citations, I would welcome you to get in touch and we can arrange a meeting to discuss accordingly. I would like to be done with this issue and I assume you would like to stop receiving these letters as well.

You may contact me at (320) 252-6822 or jon.noerenberg@ci.waitepark.mn.us with any questions or to arrange meeting to discuss.

Sincerely,

Jon Noerenberg
Planning & Community Development Director



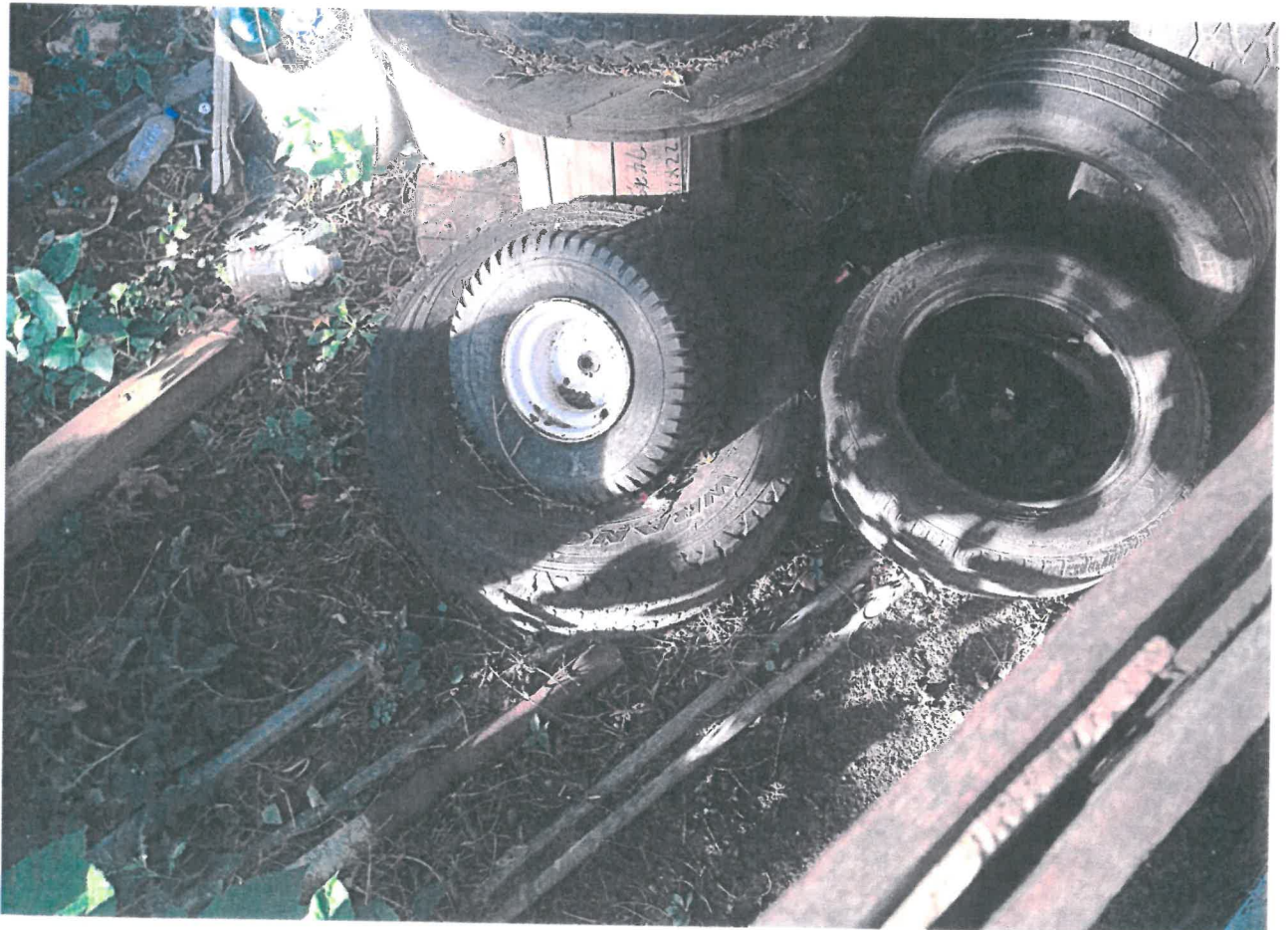







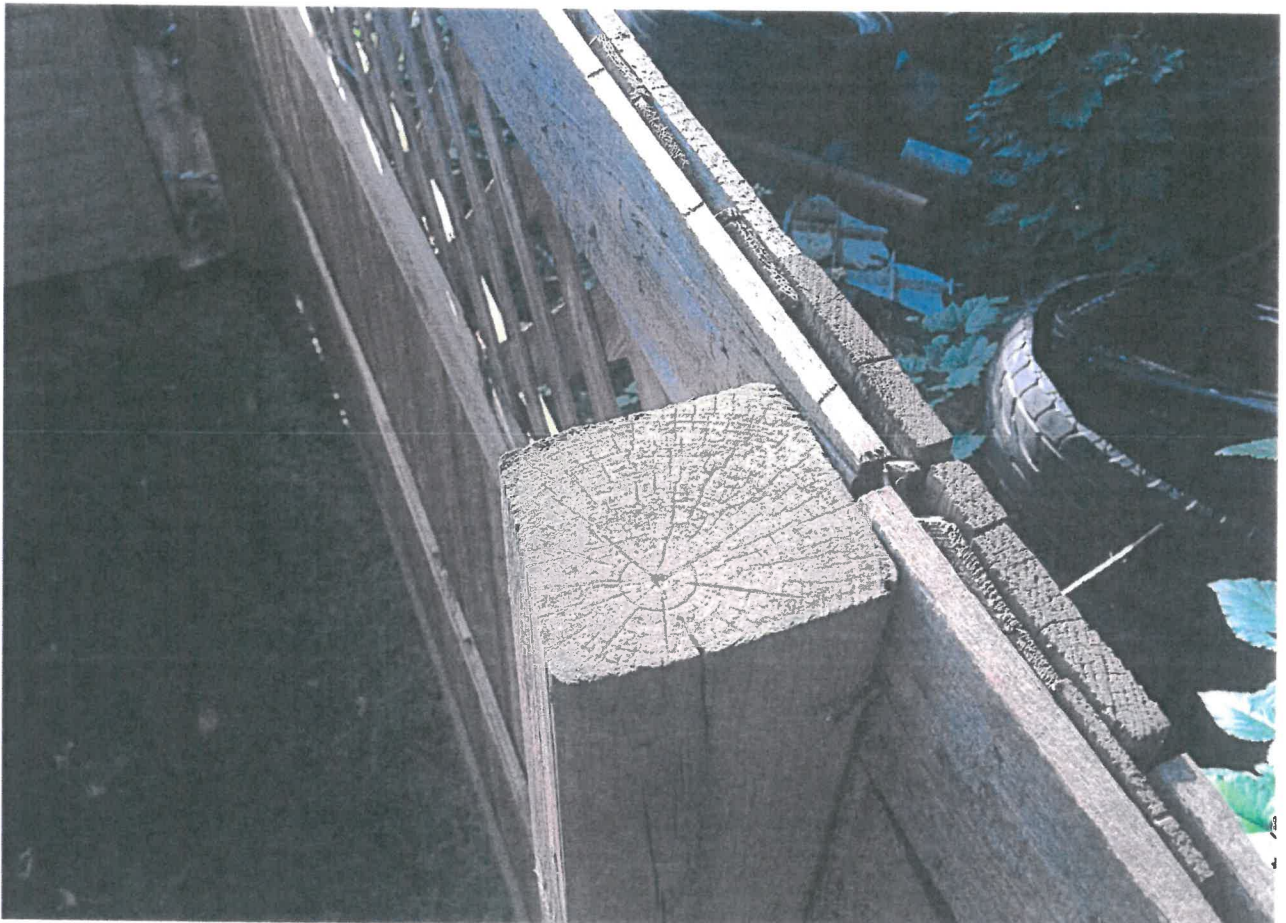

Agenda Item No. 6

Issue: Poganski Automotive CUP – 408 3rd Street North, Waite Park, Minnesota

BACKGROUND: Dale Poganski and Annette Poganski, husband and wife, own as joint tenants the property located at 408 3rd Street North, Waite Park, Minnesota, legally described as follows:

Lots 1, 2, 3, 4, 5, and 6, Block 6, Townsite of Waite Park,
according to the plat thereof on file and of record in the office of
the County Recorder in and for Stearns County, Minnesota.

Mr. Poganski has been contacted several times by Jon Noerenberg, the Planning and Community Development Director, acting as the Building/Code Enforcement Officer. Records indicate this matter has been reviewed at City Council meetings for continual noncompliance four times since its initial approval. On April 28, 2017, Mr. Poganski was served via certified mail, notifying him of the specific noncompliance issues on the above described property. Mr. Poganski was asked to submit a plan which would bring said property back into compliance with the terms of the Conditional Use Permit by May 15, 2017. Mr. Poganski did not submit any plan. The most recent contact was by letter from Jon Noerenberg to Mr. Poganski served via registered mail on September 7, 2017, notifying Mr. Poganski of the scheduled hearing on September 18, 2017. As of September 8, 2017, the nuisance conditions and noncompliance issues still exist on the above described property. Jon Noerenberg is requesting the conditional use permit be revoked against the above described property.

REQUIRED ACTION: Approve OR Deny the resolution to revoke the Conditional Use Permit granted on the above described property.

RECOMMENDED ACTION: Decision is up to the Council.

SUGGESTED MOTION: Council Member _____ moved to approve OR deny the resolution to revoke the conditional use permit granted on the above described property.

Council Member _____ seconded the motion.

ROLL CALL

Council member Charles Schneider _____
Council member Vic Schulz _____
Council member Michael Linquist _____
Council member Frank Theisen _____
Mayor Richard E. Miller _____

Motion (Approved) (Denied)

RESOLUTION NO. _____
CITY OF WAITE PARK

WHEREAS, the City Council has heard and read the report of Jon Noerenberg, the Planning and Community Development Director acting as the Building/Code Enforcement Officer, regarding nuisance conditions on the property located at: 408 3rd Street North, Waite Park, Minnesota, legally described as follows:

Lots 1, 2, 3, 4, 5, and 6, Block 6, Townsite of Waite Park, according to the plat thereof on file and of record in the office of the County Recorder in and for Stearns County, Minnesota;

and

WHEREAS, the City Council has conducted a duly noticed public hearing on the revocation as hereinafter defined at which the views of all interested parties were heard; and

NOW, THEREFORE, BE IT RESOLVED by the City Council of the City of Waite Park, Stearns County, Minnesota, as follows:

1. Findings.

- a) A Conditional Use Permit was recorded on the above described property granting Dale Poganski, the owner of said property, a conditional use permit for a car repair business and related uses.
- b) Dale Poganski has been contacted several times since being granted the Conditional Use Permit. Mr. Poganski was most recently contacted via certified mail on April 28, 2017, and via registered mail on September 7, 2017.
- c) The most recent letter dated September 7, 2017 notified Mr. Poganski of the nuisance issues and noncompliance of terms of the Conditional Use Permit and gave notice of the hearing date scheduled for September 18, 2017 at 6:30 p.m. at the Waite Park City Hall, 19 13th Avenue North, Waite Park, Minnesota.
- d) The conditions present on the above described property are not in compliance with the terms of the Conditional Use Permit.
- e) As of September 7, 2017, the nuisance conditions and noncompliance issues with the Conditional Use Permit still exist on the above described property.
- f) This property has repeatedly been out of compliance with the Conditions of the Permit.

2. Revocation.

- a) In accordance with Ordinance 52.51.02, subdivision 5 of the City of Waite Park's Code of Ordinances, the Conditional Use Permit has expired based upon the noncompliance with the terms of the Conditional Use Permit.
- b) The City of Waite Park is authorized to revoke the Conditional Use Permit granted on the above described property.

Adopted by the City Council this ____ day of September, 2017.

September 18, 2017

Shaunna Johnson
City Administrator

Richard E. Miller
Mayor

ACTON ON THIS RESOLUTION:

Motion for adoption:

Seconded by:

Voted in favor of:

Voted Against:

Abstained:

Absent:

Resolution adopted.

I hereby certify that the foregoing is a true and correct copy of a resolution adopted by the Waite Park City Council at a duly authorized meeting held on September ____, 2017.

Shaunna Johnson
City Administrator



September 7, 2017

Poganski Automotive
408 3rd St N
Waite Park, MN 56387

****REGISTERED MAIL RECEIPT REQUESTED****

Re: Notice of City Council Review and Recommendation of Conditional Use Permit Revocation

Mr. Poganski,

This letter serves as notice that the City of Waite Park will be scheduling a City Council review for your property at 408 3rd Street North, due to continued nuisance issues and non-compliance with multiple correction orders issued by City staff. Per City Ordinance 52.51.02, Subdivision 5, a conditional use permit authorize sonly the conditional use specified in the permit and expires if, for any reason, the conditions of approval are not met and/or maintained.

I have scheduled a review with the City Council regarding your Conditional Use Permit non-compliance and failure to take action, submit plans, or otherwise make contact with me to discuss plans bring your property into compliance as per previous correspondence.

Given that these are recurring issues since the initial granting of the Conditional Use Permit, and your previous appearances to discuss the same with the City Council, I am requesting and recommending that the City Council take formal action to revoke your Conditional Use Permit.

The review will take place at the following meeting. You may attend this meeting if you so choose.

Regular City Council Meeting
Waite Park City Hall – 19 13th Ave N, Waite Park, MN 56387
Monday, September 18th, 2017
Starting at 6:30PM

You may contact me at (320) 656-8936 or jon.noerenberg@ci.waitepark.mn.us with any questions.

Sincerely,

Jon Noerenberg
Planning & Community Development Director



October 20, 2016

Poganski Automotive
408 3rd St N
Waite Park, MN 56387

Re: Reminder of Terms of Conditional Use Permit

Dear Mr. Poganski,

It has come to my attention that Poganski Automotive may not be complying with all the terms of approval of your Conditional Use Permit from 1998. In reviewing the files for your property, I found that my predecessor had numerous contacts with you over a period of years regarding these same issues. Given the number of vehicles on your property it appears that your business has been growing and this may have led to some of the terms of the City approval falling by the wayside.

I would encourage you to review the enclosed Conditional Use Permit resolution which outlined the terms of approval of your business. These include such issues as ensuring that no auto body work is taking place, no outside storage of dismantled vehicles or parts, and the condition that no vehicle is to be parked outside more than ten days. The fence in the rear of the building adjacent to the alley is also in need of minor repair. As outlined in previous correspondence, truck beds or interiors of vehicles also may not be used for any form of storage.

Please review and resolve any issues as outlined above by December 1st. You are welcome to contact me to discuss any specific questions or to lay out a plan to bring your property into compliance. I would like to avoid the repeat violation notices of the past and it would seem you have an understanding of the City's expectations for property conditions given your previous contacts with Bill Barber.

Please feel free to contact me at (320) 656-8936 or jon.noerenberg@ci.waitepark.mn.us with any questions or to discuss further. Your timely cooperation is appreciated.

Sincerely,

Jon Noerenberg
Planning & Community Development Director



April 28, 2017

Poganski Automotive
408 3rd St N
Waite Park, MN 56387

****CERTIFIED LETTER RECEIPT REQUESTED****

Re: Conditional Use Permit Compliance – Need to Correct

Mr. Poganski,

In October 2016 I sent a reminder letter to you regarding the terms of the Conditional Use Permit that was approved for your property in 2008. I asked that you review the terms of this approval and ensure that your property meets all requirements by December 1st. To date I have not seen any progress.

As outlined previously, given the correspondence we have on file it seems you are well aware of the terms of the Conditional Use Permit, which include such issues as ensuring that no auto body work is taking place, no outside storage of dismantled vehicles or parts, and the condition that no vehicle is to be parked outside more than ten days. In reviewing the property and aerial images, there are vehicles which have been on the property for at least two years at this point.

You need to provide a plan to correct these issues. Several City Council members have commented on the poor condition of the property and the issues of non-compliance and if necessary I am certain they will be willing to consider revoking the Conditional Use Permit upon my recommendation. As with the previous letter, I am again enclosing a copy of the Conditional Use Permit for your review and use.

Please submit a plan for bringing the property into compliance and maintaining it as such for my review and consideration by May 15th, 2017. Imperative issues are property clean-up and revising your standards for storage of vehicles on-site. You may also contact me to set up a meeting to discuss. I am willing to work with you but if the property is not either brought into compliance or a plan not provided as above by the May 15th deadline I will begin process of reopening the Conditional Use Permit for reconsideration due to noncompliance.

Please feel free to contact me at (320) 656-8936 or jon.noerenberg@ci.waitepark.mn.us with any questions or to discuss further. Your cooperation if this matter is appreciated.

Sincerely,

Jon Noerenberg
Planning & Community Development Director

178 (21)

408-3rd St N.

888757

98 OCT 16 PM 12:58

COUNTY RECORDER
STEARNS CO. MN
PATRICIA M. OVERMAN
BY *Mlong* DEPUTY

CONDITIONAL USE PERMIT

PLEASE TAKE NOTICE that the City of Waite Park, a municipal corporation under the laws of the State of Minnesota, by and through its City Clerk, Jeffrey J. Baird, does certify that the Waite Park City Council did, on the 8th day of September, 1998, grant to Dale Poganski, the owner of property described as follows:

Lots 1, 2, 3, 4, 5 and 6, Block 6, Townsite of Waite Park, according to the plat thereof on file and of record in the office of the County Recorder in and for Stearns County, Minnesota,

a Conditional Use Permit for a car repair business and related uses.

This Conditional Use Permit variance is subject to the following conditions:

1. The property owner shall be required to provide a natural barrier to protect the neighborhood by installing a six (6) foot wood fence on the south property line, and preserving the existing landscaping on the east and west property line.
2. The property owner shall construct a building with earth tone colors and shall include a gable roof to blend into the existing neighborhood.
3. The use of the property shall be strictly limited to mechanical repair. Auto body repair and auto sales are prohibited.
4. All cars in the state of repair shall be located behind the front yard setback area.
5. Business hours shall be limited to Monday through Saturday from 8:00 a.m. until 6:00 p.m.

June 1st 2017

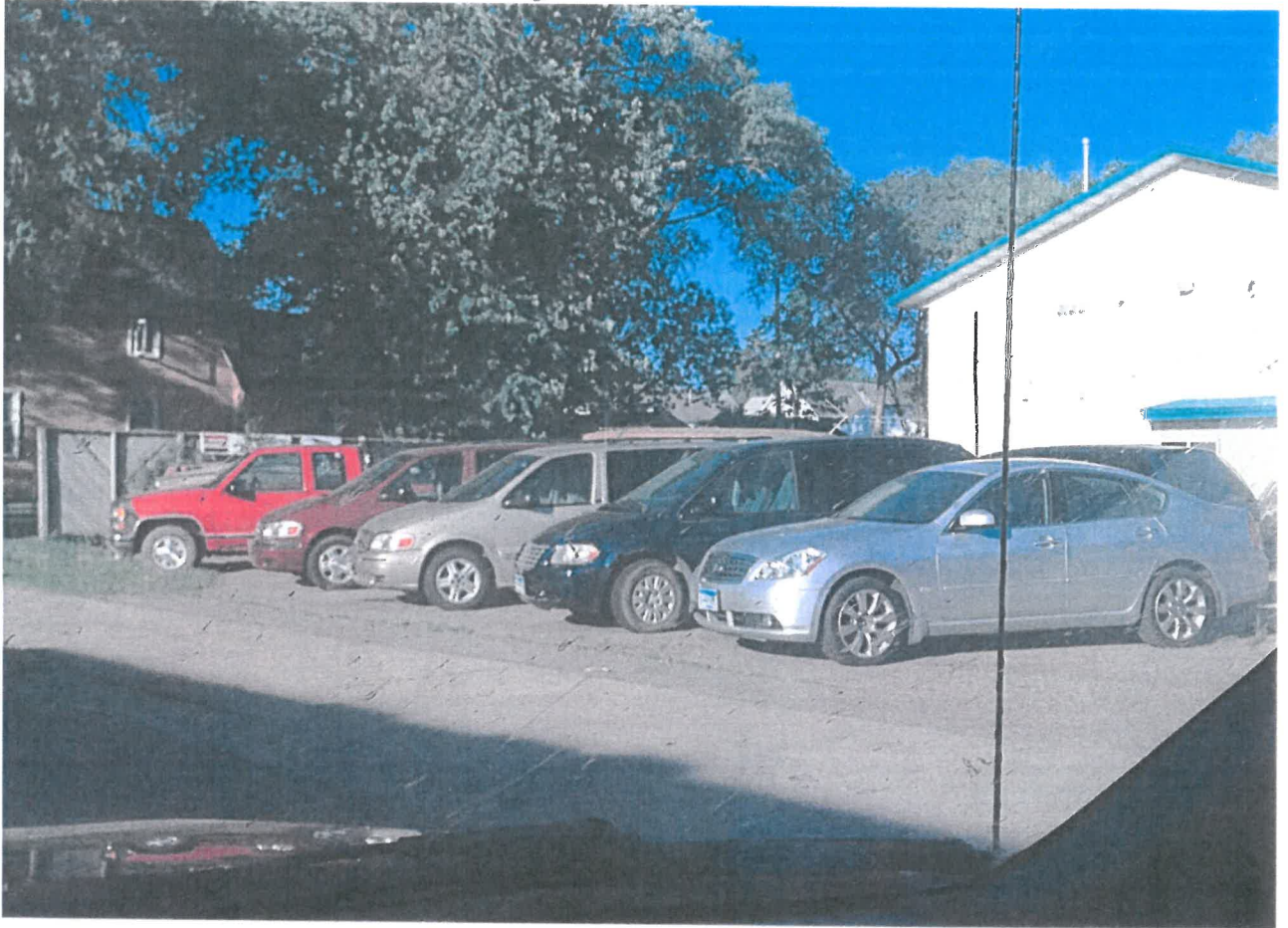

June 1st 2017



July 17th 2017



July 17th 2017



July 17th 2017

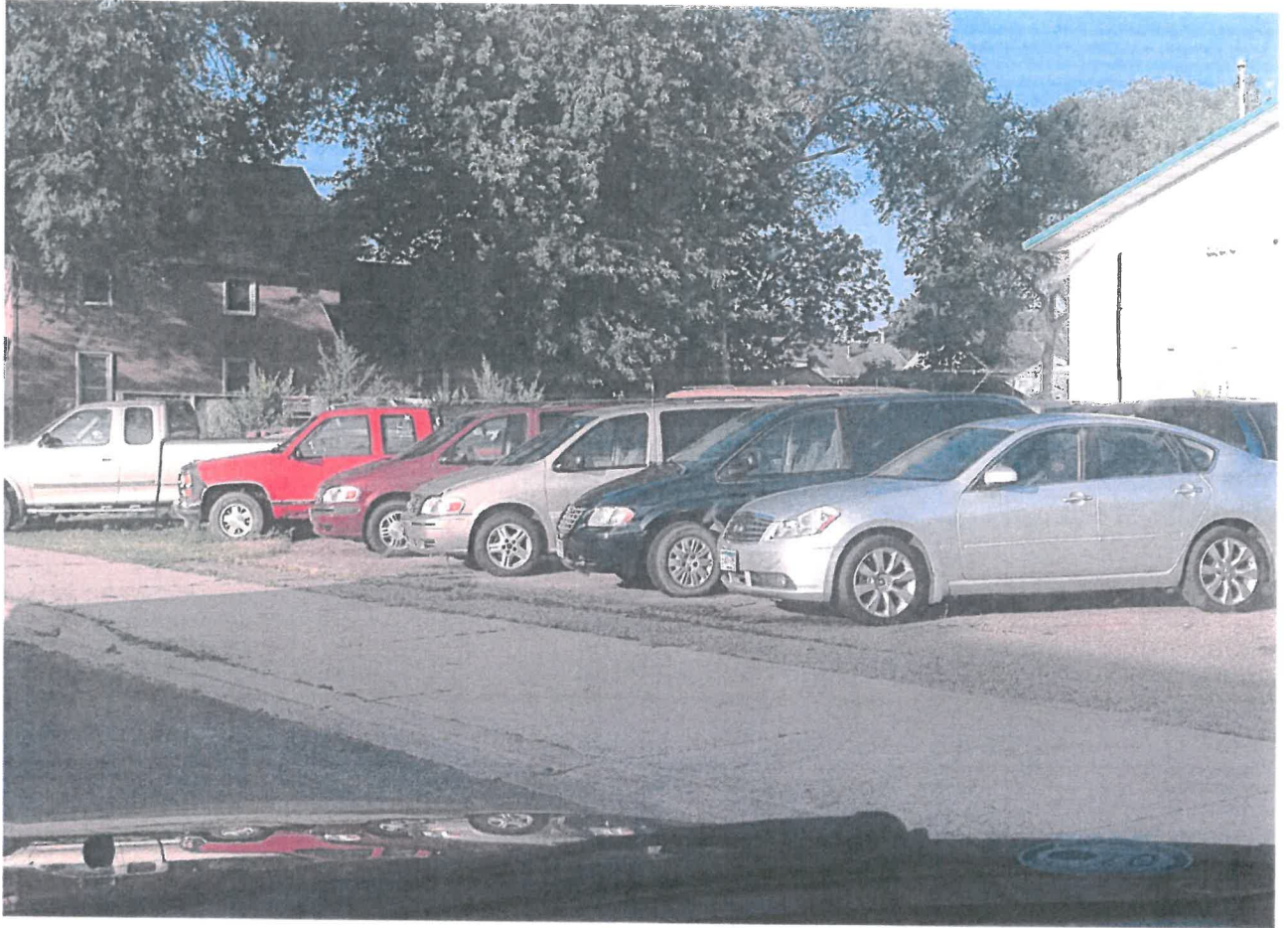

July 25th, 2017



July 25th, 2017



August 9th 2017



August 9th, 2017



August 9th, 2017



August 18th, 2017



August 18th, 2017



August 18th, 2017



July 31st, 2017



July 31st, 2017



July 31st, 2017



September 15th, 2017



September 1st, 2017



September 1st 2017



September 12th 2017



September 12th, 2017



Agenda Item No. 7

Issue: Water Tower Maintenance Agreement Contract

BACKGROUND:

Attached is the Water Tank Maintenance Agreement with the terms and conditions as discussed at the previous council work session. The Agreement calls for the work to be completed by July 1, 2018, with three equal payments over three years beginning in July of 2019. The tower will be painted according to the consensus design agreed to at the work session (image attached as Exhibit C). We have included an option for painting three “Waite Park” logos.

REQUIRED ACTION:

Approve the attached Water Tank Maintenance Agreement

RECOMMENDED ACTION:

Approve.

SUGGESTED MOTION:

Council member _____ moved to approve the Water Tank Maintenance Agreement as presented OR with the following revisions/corrections/ additions: _____

Council member _____ seconded the motion.

ROLL CALL

Councilmember Charles Schneider _____
Councilmember Vic Schulz _____
Councilmember Mike Linquist _____
Councilmember Frank Theisen _____
Mayor Richard E. Miller _____

Motion (Approved) (Denied)

AGREEMENT

THIS WATER TANK MAINTENANCE SERVICES AGREEMENT (hereinafter called "Agreement") is made as of the ____ day of _____, 20__ (the "Effective Date") by and between the City of Waite Park, MN (hereinafter called "Owner" or "City") and SEH Design/Build, Inc., with its principal place of business at St. Paul, Minnesota (hereinafter called "SEH D|B").

In consideration of the agreements hereinafter contained, the parties hereto agree as follows:

1. SCOPE OF SERVICES

The Owner retains SEH D|B to furnish the services set forth on the attached Exhibit "A" (referred to as "Services" or "Work"). SEH D|B agrees to perform the services. SEH D|B shall provide all personnel, supervision, services, materials, tools, equipment and supplies and do all things necessary for the Water Tank Services and all materials, equipment and improvements ancillary thereto specified on Exhibit "A" (Sometimes referred to herein as "the Project").

The Project bound by this Agreement is:

The 500,000-gallon single pedestal water tank adjacent to 801 Sundial Drive

The work to be performed under this Agreement shall be done under the review of a professional engineer licensed in the State of Minnesota, who shall attest that the work will be performed in compliance with all applicable codes and engineering standards.

All procurement and construction shall be in accordance with drawings, specifications or other documents to be prepared by SEH D|B in accordance with design premises, performance requirements and other criteria set forth or referenced in the Exhibits hereto. The work shall be performed as set forth in the Contract Documents, which includes this Agreement and Exhibits, including Exhibit "A" – Schedule and Scope of Services and Exhibit "B" – Compensation Schedule. In the event any ambiguity or conflict between the Contract Documents listed above, the order of precedence shall be the following order: (i) this Agreement; (ii) Exhibit "A", (iii) Exhibit "B".

2. REPRESENTATIVES

Owner has designated _____ (name), _____ (title) for the City of City of Waite Park, MN (the "Owner Representative"), and SEH D|B has designated Mr. Steve Peterson (the "SEH D|B Representative"). The Owner Representative and the SEH D|B Representative shall be available as often as is reasonably necessary for reviewing the Water Tank Services herein, providing required information or decisions, and for authorizing changes therein as may be required.

3. COMPENSATION

SEH D|B shall be paid by the Owner for the services described in paragraph 1 (further described in Exhibit A) in accordance with the amounts designated in Exhibit B for each year of service, inclusive of reimbursable costs.

4. INVOICING

- 4.1 The invoice for the first year fee will be submitted upon completion of the work done in the first year. Invoices for the subsequent fees will be submitted in the anniversary month of this Agreement.
- 4.2 Invoices for change orders shall be separately mailed and billed as outlined in the Change Order.
- 4.3 Amounts more than 30 days past due shall accrue interest at the lesser of 1.5% per month or at the maximum rate allowed by law. If the Owner fails to make timely payment, SEH D|B may suspend work until receipt of payment.
- 4.4 Invoices for services required for the engineering, repair and services required to bring the water tank or appurtenant facilities into compliance with applicable federal, state and local codes shall be separately itemized by SEH D|B and payment shall be spread over a period of not less than three years from the Effective Date.
- 4.5 The maximum payment due from the Owner shall not exceed the total Water Utility Charges and fees collected by the Owner in the ordinary course of business.

5. COMPLETION

SEH D|B has prepared a schedule in the attached Exhibit A that identifies the duration of the contract, including the overall contract length and intermediate project milestones and completion dates. This schedule is subject to adjustment as allowed or required by this Agreement, the Owner, and SEH D|B.

6. SUBCONTRACTING

The subcontracting of any portion of the Work shall not relieve SEH D|B of responsibility for the performance of the Work, as provided hereunder. However, SEH D|B shall have the right to subcontract such portions of the Work as it shall determine to others, including any affiliates of SEH D|B ("Affiliates").

7. OWNER RESPONSIBILITIES

7.1 TELECOMMUNICATIONS

- 7.1.1 Owner recognizes that any telecommunications equipment located on the water tank(s) or appurtenant facilities may interfere with the work contemplated in this Agreement. If requested by SEH D|B, Owner agrees to arrange for the owner of any telecommunications equipment located on the water tank(s) or appurtenant facilities to remove or protect telecommunications equipment during the Work. SEH D|B cannot and will not remove such equipment and the removal of such equipment by the Owner or the owner of such equipment is a condition precedent to SEH D|B's obligations under this Agreement.
- 7.1.2 Owner will also arrange for the reinstallation of the telecommunications equipment after SEH D|B has notified the Owner that rehabilitation work has been completed or that the work has proceeded to the point where such equipment may be reinstalled. SEH D|B shall have no responsibility for the reinstallation of the telecommunications equipment.
- 7.1.3 Owner acknowledges that SEH D|B cannot be responsible for any damage to the telecommunications equipment during the removal and reinstallation of the existing equipment. As a result, Owner will indemnify, defend and hold SEH D|B harmless against any and all claims, damages, suits, disbursements or other costs including reasonable attorneys' fees incurred by SEH D|B as a result of removal and/or reinstallation of the existing telecommunications equipment.
- 7.1.4 Work that results from the proposed or actual installation of future telecommunications or other equipment that is anchored to or otherwise attaches to the tank structure or appurtenances is not included as part of this work. Owner agrees that SEH D|B will have the right to review, approve and inspect all proposed/future telecommunications equipment installations during the term of this

contract. SEH D|B shall be compensated in accordance with its then current hourly rates for such work as an additional service. SEH D|B shall bill Owner for these services through a separate invoice for this work.

7.2 PROJECT INFORMATION

7.2.1 The Owner shall furnish all surveys, record drawings, and other information describing legal limitations, physical conditions, soils and subsurface conditions and utility locations material to the Work. The Owner shall provide SEH D|B with copies of all prior evaluations, studies, reports, or existing documentation regarding the condition of Water Tanks, or any concerns or complaints regarding the condition or operation of the Tank(s) or other work subject to this Agreement. The Owner shall secure and pay for necessary permits, approvals, variances, easements, assessments and charges required for the construction, use or occupancy of the Water Tank. If the Owner becomes aware of any fault or defect in the Project, it shall give prompt notice thereof to SEH D|B.

8. INDEMNIFICATION

To the fullest extent permitted by law, SEH D|B agrees to defend and indemnify the Owner, and its officers, employees, agents, contractors, volunteers and public officials, from and against all claims, damages, losses, and expenses, including attorney fees, attributable to the negligent, or otherwise wrongful act or omission, including breach of a specific contractual duty, of SEH D|B, its employees, agents, contractors, or delegates under this Agreement.

9. INSURANCE

SEH D|B shall secure and maintain such insurance as will protect SEH D|B from claims under the Worker's Compensation Acts, automobile liability, and from claims for bodily injury, death, or property damage which may arise from the performance of services under this Agreement. Such insurance shall be written for amounts not less than:

Commercial General Liability	\$1,000,000 each occurrence/aggregate
Automobile Liability	\$1,000,000 combined single limit
Excess/Umbrella Liability	\$2,000,000 each occurrence/aggregate

The Owner shall be named as an additional insured on the general liability and umbrella policies. The Commercial General Liability policy shall include coverage for premises, operations, personal injury, advertising injury and contractually assumed liability.

SEH D|B or its engineering subconsultant shall secure and maintain a professional liability insurance policy. Said policy shall insure payment of damages for legal liability arising out of the performance of professional services for the Owner, in the insured's capacity as engineer, if such legal liability is caused by a negligent act, error or omission of the insured or any person or organization for which the insured is legally liable. Said policy shall provide minimum limits of \$1,000,000 with a deductible maximum of \$200,000 unless the Owner agrees to a higher deductible.

Before commencing work, SEH D|B shall upon written request, provide the Owner a certificate of insurance evidencing the required insurance coverage in a form acceptable to Owner. The certificate shall provide that such insurance cannot be cancelled until thirty (30) days after the Owner has received written notice of the insurer's intention of cancel this insurance.

10. INDEPENDENT CONTRACTOR

The Owner hereby retains SEH D|B as an independent contractor upon the terms and conditions set forth in this Agreement. SEH D|B is not an employee of the Owner and is free to contract with other entities as provided herein. SEH D|B shall be responsible for selecting the means and methods of performing the work. SEH D|B shall furnish any and all supplies, equipment, and incidentals necessary for SEH D|B's performance under this Agreement. Owner and SEH D|B agree that SEH D|B shall not at any time or in any manner represent that SEH D|B or any of SEH D|B's agents or employees are in any manner agents or employees of the Owner. SEH D|B shall be exclusively responsible under this Agreement for SEH D|B's own FICA payments, workers compensation payments, unemployment compensation payments, withholding amounts, and/or self-employment taxes if any such payments, amounts, or taxes are required to be paid by law or regulation.

SEH D|B agrees to comply with all federal, state, and local laws and ordinances applicable to the services begin performed under this Agreement, including all safety standards. SEH D|B shall be solely and completely responsible for conditions of the job site, including the safety of all persons and property during the performance of the services. SEH D|B represents and warrants that it has the requisite training, skills, and experience necessary to provide the services and is appropriately licensed by all applicable agencies and governmental entities to provide such services.

11. CHANGE ORDERS

- 11.1 The Owner may request that SEH D|B perform additional services not originally included in the basic services identified in Exhibit A. No such work may be done until after the Owner has approved the change order in writing. Upon such a request by Owner, SEH D|B will generate a Change Order in writing describing the additionally requested Work and the anticipated compensation for undertaking that Work. .
- 11.2 In any emergency affecting the safety of persons or property, SEH D|B shall act, at its discretion, to prevent threatened damage, injury or loss. If the emergency was not the result of SEH D|B's fault, SEH D|B will be entitled to an equitable contract adjustment to compensate SEH D|B for its services.
- 11.3 All Change Orders shall include:
 - 11.3.1 A detailed description of the Change Order Work to be performed.
 - 11.3.2 The amount of any adjustment (up or down) to the SEH D|B contract for the Work done pursuant to Change Order.
 - 11.3.3 A modification of the project schedule if necessitated by the Change Order Work.
- 11.4 SEH D|B may request a change order if it believes work outside the scope of services has been requested or is needed. All such change orders must be approved in writing by the Owner before the work is done.

12. TERM AND TERMINATION

- 12.1 Either party may terminate this Agreement prior to the expiration of the 10-year term for material breach of this Agreement, provided such breach is not cured as set forth below.
- 12.2 If either party believes that the other has materially breached the agreement, then the party alleging the breach shall give the other 15 days written notice setting forth the nature of the claimed breach and confirming the intent to terminate. The party claimed to be in breach will then have 15 days to cure the condition which constitutes the alleged material breach of the contract, or demonstrate that no breach exists. If the party in breach fails to correct the breach or demonstrate no breach exists, the agreement will terminate upon two days written notice.
- 12.3 The Owner may, at any time, terminate this Agreement for the Owner's convenience without cause upon 30 days written notice. In the event the Owner terminates this Agreement for convenience, SEH D|B shall:
 - 12.3.1 Cease operations as directed by the Owner in its notice;
 - 12.3.2 Take actions as necessary or as the Owner may direct for the protection and preservation of the Work; and

- 12.3.3 Except for work directed to be performed prior to the effective date of the termination for convenience, terminate all existing subcontracts and purchase orders, and enter in to no further subcontracts and purchase orders.
- 12.3.4 Determine the total amount due for services performed prior to the effective date of the termination for convenience.
- 12.4 In the event of termination for convenience by the Owner, SEH D|B shall be entitled to receive payment for all Work satisfactorily performed through the date of termination, including any Change Orders.
- 12.5 In the event of termination for cause prior to the expiration of the term of this Agreement or any Work Order, Owner shall pay to SEH D|B the remaining amount due for the Work satisfactorily performed and all claims shall be resolved as set forth in the applicable Work Order. Such payment shall be due within 30 days of termination. Payments not received by the last day of the month shall be overdue and will accrue interest at a rate of 1.5% per month or the maximum rate allowed by law whichever is less.

13. ASSIGNMENT

Neither party shall assign this Agreement, nor any interest arising herein, nor any claims arising from or related to this Agreement or the Project, without the written consent of the other party. Any assignment in violation of this provision shall be null and void. Notwithstanding the above, SEH D|B reserves the right to assign its right(s) for payments due under this Agreement to a bank, credit union or other lending institution or entity in return for immediate payments, financing of work under this Agreement or other good and valuable consideration, and Owner hereby consents to such assignment.

14. WAIVER

Any waiver by either party of a breach of any provisions of this Agreement shall not affect, in any respect, the validity of the remainder of this Agreement.

15. ENTIRE AGREEMENT

The entire agreement of the parties is contained herein. This Agreement supersedes all oral agreements and negotiations between the parties relating to the subject matter hereof as well as any previous agreements presently in effect between the parties relating to the subject matter hereof. Any alterations, amendments, deletions, or waivers of the provisions of this Agreement shall be valid only when expressed in writing and duly signed by the parties, unless otherwise provided herein.

16. CONTROLLING LAW

This Agreement shall be governed by and construed in accordance with the laws of the State of Minnesota. All parties to this Agreement consent to and accept the personal jurisdiction of the State of Minnesota and agree that all claims, disputes or litigation that arises from or relates to this Agreement shall be made in the State of Minnesota.

17. COPYRIGHT

SEH D|B shall defend actions or claims charging infringement of any copyright or patent by reason of the use or adoption of any designs, drawings or specifications supplied by it for the Project, and it shall hold harmless the Owner from loss or damage resulting there from for use of these documents for the Project. Owner shall not use any designs, drawings or specifications supplied by SEH D|B for any other project without the express written consent of SEH D|B.

18. RECORDS

SEH D|B shall maintain complete and accurate records of time and expense involved in the performance of services. SEH D|B agrees to maintain all data regarding the services, the Work and the Project pursuant to the Minnesota Government Data Practices Act, Minnesota Statute Chapter 13.

19. BINDING EFFECT, THIRD PARTIES

Each of the provisions of the Contract Documents shall extend to and shall, as the case may require, bind or inure to the benefit not only of the parties, but also for their respective successors, heirs or assigns, provided this clause shall not permit any assignment by any party of the Contract Documents not otherwise permitted. The parties agree that the Contract Documents are not intended by either party to give any benefits, rights, privileges, actions or remedies to any person, partnership, firm or corporation (other than a party or its permitted assignee, or, to the extent applicable, any Affiliates) as a third party beneficiary or otherwise under any theory of law.

20. WARRANTY

The projects identified in Section 1 of this Agreement, and the workmanship of the work tasks identified in Exhibit A of the Appendix, are hereby warranted for the term of the maintenance contract, as specified in Exhibit B of the Appendix.

SEH D|B hereby warrants the Scope of Services identified in Exhibit A of the Appendix will be completed with reasonable care and skill, such that the resultant applied coating system will perform satisfactorily for the duration of the Agreement.

21. MISCELLANEOUS

- 20.1 This Agreement states the integrated and complete Agreement between Owner and SEH D|B on this subject and replaces any previous understandings, representations or communications, whether oral or written.
- 20.2 A party's failure to exercise a right in one or many instances does not waive that right as to any later instance. The course of conduct does not affect a modification or a waiver unless ratified in writing by the party to be bound.
- 20.3 In the event of any litigation between the parties related to this Agreement or its breach, each party will be responsible for its own attorney's fees together with expert's fees and other costs.
- 21.4 The section headings of this Agreement are included for purposes of convenience only and will not affect the construction or interpretation of any provision.
- 20.5 All provisions of this Agreement allocating responsibility between the Owner and SEH D|B will survive the completion of the Work or termination of this Agreement.
- 20.6 Any provision or part of this Agreement adjudicated to be void or unenforceable under any law will be deemed deleted, such deletion to apply only with respect to the jurisdiction in which such adjudication is made, and all remaining provisions will continue to be valid and binding upon the parties. The parties agree that this Agreement will be reformed to replace the deleted provision or part thereof with a valid and enforceable provision that comes as close as possible to expressing the intention of the deleted provision.
- 20.7 SEH D|B warrants and guarantees to the Owner that all material and work will be in accordance with the contract documents and will not be defective. SEH D|B shall provide a manufacturer's warranty on paint of at least ten years in a form acceptable to the Owner.
- 20.8 In the hiring of employees or subcontractors to perform work under this Agreement, SEH D|B shall not discriminate against any person by reason of any characteristic protected by state or federal law.

20.9 All notices and other communications under this Agreement must be in writing and must be addressed as follows:

Notice to Owner: City of Waite Park, Minnesota
Attn: _____
19 13th Avenue North
City of Waite Park, MN 56387

Notice to SEH D|B SEH Design/Build, Inc.
Attn: Steve Peterson, SEH D|B President
3535 Vadnais Center Drive
St. Paul, MN 55110

IN WITNESS WHEREOF, the parties hereto through their respective authorized representatives have executed this Agreement as of the day and year first written above.

OWNER

SEH DESIGN|BUILD, INC.

BY: _____
City of Waite Park, MN

BY: _____
Steve Peterson, President

BY: _____

Its: _____

Dated: _____

Dated: _____

EXHIBIT A-1

SCHEDULE OF SERVICES

WAITE PARK, MINNESOTA		MAINTENANCE PLAN YEAR									
		1	2	3	4	5	6	7	8	9	10
		2018	2019	2020	2021	2022	2023	2024	2025	2026	2027
REHABILITATION											
New Coating System	(Exterior)	●									
	(Wet Interior)	●									
	(Dry Interior)	●									
Accessory Modifications and Repairs		●									
Quality Assurance Inspections		●									
VISUAL SURVEY											
Coating Observation	(Exterior)		●	●							
	(Wet/Dry Interior)		●	●							
Accessory Observation			●	●							
Summary Statement			●	●							
Pressure Wash	(Exterior)										
	(Wet Interior)										
Spot Coating Repairs	(Exterior)										
	(Wet/Dry Interior)										
Minor Accessory Repairs											
Quality Assurance Inspections											
Coating Testing and Analysis	(Exterior)				●						
	(Wet/Dry Interior)				●						
Five-year AWWA Inspection					●						
Tank Accessories Inspection					●						
Report with Recommendations					●						

EXHIBIT A-2

SCOPE OF SERVICES

Tank Name:	South (Smiley) Tank 500,000-Gallon Elevated Single-Pedestal Tank Waite Park, Minnesota
Year: 2018	
1.	Exterior (Structural): <ul style="list-style-type: none"> • Clean-out overflow and replace screen with stainless steel mesh. • Remove existing obstruction light and install new LED obstruction light. • Remove drain lines adjacent to overflow and patch base cone. • Replace roof manway gaskets. • Replace roof locks.
2.	Exterior (Coatings): <ul style="list-style-type: none"> • Erect a fully flexible containment system with a roof bonnet. • Complete removal of the existing coating system on the exterior surfaces to an equivalent of an SSPC-SP6 Commercial Blast Cleaning condition. • Apply one coat of zinc primer, one coat of epoxy, and one coat of urethane with UV protection (AWWA D102 Outside Coating System No. 6). • Paint color to be designated by Owner. • The exterior logos on the tank bowl will be determined by the Owner. The identified pricing includes the image of proposed logo/design within this document. The logos will be applied using a Sherwin Williams FlouroKem product for increased color retention.
3.	Dry Interior (Structural): <ul style="list-style-type: none"> • Remove and reinstall existing safety climb devices. • Repair bowl drain penetration and replace drain valve with Babco model. • Remove existing platform drain lines and attach drain lines to overflow. • Repair ladder stand-off bracket. • Replace existing manway gaskets. • Replace all non-functional interior light bulbs with LED bulbs. • Remove surface imperfections by torch, arc gouging, or grinding. • Install city-issued locks.
4.	Dry Interior (Coatings): <ul style="list-style-type: none"> • Complete removal of the existing dry interior coating system to an equivalent of a SSPC-SP6 Commercial Blast Cleaning condition. • Apply one coat of zinc primer and two coats of epoxy to all dry interior surfaces.
5.	Wet Interior (Structural): <ul style="list-style-type: none"> • Install a grate over the existing fill pipe in accordance with AWWA guidelines. • Seal the gaps in the lapped plates, including the collar-to-roof plate, and roof-to-roof radial torus plates (seams above the normal water line) with elastomeric caulk to inhibit rust bleed. • Seal any/all roof openings and other roof penetrations with elastomeric caulk. • Replace all gaskets and hardware on manways.

Tank Name:	South (Smiley) Tank 500,000-Gallon Elevated Single-Pedestal Tank Waite Park, Minnesota
6.	Wet Interior (Coatings): <ul style="list-style-type: none"> • Remove the existing coating system within the wet interior to the equivalent of an SSPC-SP10 Near-White Blast Cleaning condition. • Remove any surface discontinuities such as erection marks, weld spatter, and sharp fins. Re-blast to create surface profile, as needed. • Apply one coat of zinc primer and two coats of epoxy-polyamide to entire wet interior. • Disinfect the wet interior of the tank per AWWA C652.

Year: 2019 and 2020	
1.	Visual Surveys: <ul style="list-style-type: none"> • Full tank inspection including exterior, wet interior, and dry interior coating systems (wet interior does not need to be drained). • Summary Report.

Year: 2021	
1.	Engineering Evaluation: <ul style="list-style-type: none"> • Full tank inspection including exterior, wet interior, and dry interior coating systems (wet interior does not need to be drained). • Five-year AWWA documentation. • Tank accessories inspection. • Preparation of summary report with recommendations.

EXHIBIT B
COMPENSATION SCHEDULE

In return for completion of the services identified in Exhibit A-1 and A-2 by July 1, 2018, the Owner agrees to compensate SEH D|B in accordance with the following schedule of payments. The first payment shall be invoiced one year after completion of the work tasks identified in 2018.

Each additional annual payment shall be invoiced on the anniversary date of the initial invoice.

Maintenance contract costs can be paid as incurred on an annual basis, or may be amortized over the ten-year maintenance plan into an equal annual payment, or an equal annual payment that is adjusted for inflation during the term of the contract.

The Owner must identify preferred payment schedule by initialing the selected payment option.

	<input type="checkbox"/>	<input type="checkbox"/>
	Rehabilitation Including Two Logos	Rehabilitation Including Three Logos
2018	\$0	\$0
2019	\$238,300	\$239,400
2020	\$238,300	\$239,400
2021	\$238,300	\$239,400
Totals:	\$714,900	\$718,200

Performance and Payment Bonds are not required for Water Tank Maintenance Service Agreements and are not included in the Compensation Schedule.

EXHIBIT C

PROPOSED PAINT SCHEME

SEH Design|Build has assisted the City of Waite Park in developing a logo to be applied upon rehabilitation of the water tank. A mock-up of the proposed logo has been included here for reference.

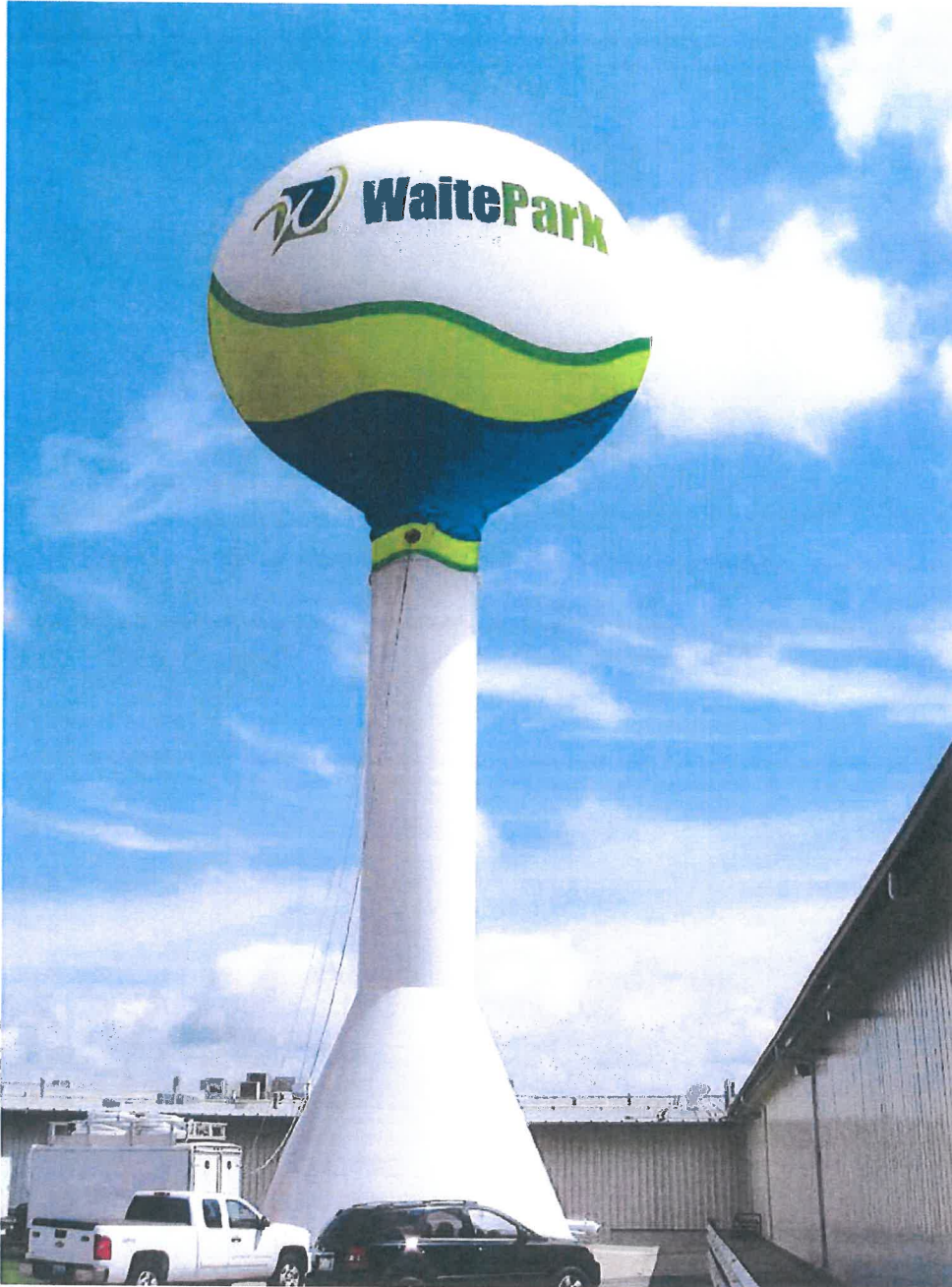

Agenda Item No. 8

Issue: Payoff Lienholder on Forfeited Vehicle

BACKGROUND:

The police department vehicle fleet currently has 9 vehicles assigned to Patrol, 2 assigned to Investigations and 3 assigned to Administration for a total of 14 vehicles. Currently, there is no need to replace patrol squads in 2018 but it is anticipated, with additional vehicle mileage, we will need to replace at least two (2) patrol squads in 2019. The police department has a unique opportunity to consider a transaction now that could reduce the number of new squads requested in 2019 to one (1).

In September 2016 the police department made a DUI arrest involving a vehicle that was eligible for forfeiture. The underlying criminal case is now resolved and the police department is able to complete the forfeiture process. Per MN forfeiture laws, forfeited vehicles can either be retained/used by the agency or sold at a public sale. Most vehicles forfeited do not have a solid police application so typically the police department sells eligible forfeiture vehicles at a public sale. The accumulated proceeds from the sale of forfeited vehicles, from time to time, are used by the department for related training and/or the purchase of patrol vehicles or related in-squad patrol equipment. In the case of forfeitures the lien holders on vehicles seized in the commission of various crimes are always protected.

The police department is now eligible to retain or sell a 2015 GMC Yukon XL (32,000 miles) with an estimated retail market value of \$45,000.00. This particular vehicle does have a department application however retaining it would require paying off the lien holder in the amount of \$14,459.27. The police department currently has over \$17,500 accumulated in its DUI Forfeiture account to cover the cost of this transaction. This approval does not involve a request for additional funds being added to the police department budget. If approved, the 2015 GMC Yukon would be assigned to Administration and a Ford Explorer SUV will be moved from Administration and assigned to Patrol. It is estimated that in 2019, under the State-bid process, the cost to replace a marked squad will be approximately \$30-35,000.00. Accordingly, the police departments Capital Outlay request for 2019 would be reduced by this amount. The interests of the lien holder necessitate taking action at this time.

REQUIRED ACTION: Approve or Deny the Request to payoff lien holder

STAFF RECOMMENDATION:

Recommends the transaction as it represents an opportunity to retain a vehicle at substantially below market cost and potentially reduce future capital outlay requests.

SUGGESTED MOTION:

Council member _____ moved to approve as presented OR with the following revisions/corrections/ additions: _____

Council member _____ seconded the motion.

ROLL CALL

Councilmember Charles Schneider _____
Councilmember Vic Schulz _____
Councilmember Mike Linqvist _____
Councilmember Frank Theisen _____
Mayor Richard E. Miller _____

Motion (Approved) (Denied)

Agenda Item No. 9

Issue: Council/Mayor: Review and Approve Bills, Other Business

Councilmember _____ moved to approve bills as presented.

Councilmember _____ seconded the motion.

ROLL CALL

Councilmember Michael Linquist	_____
Councilmember Charles Schneider	_____
Councilmember Vic Schulz	_____
Councilmember Frank Theisen	_____
Mayor Richard Miller	_____

Motion (Approved) (Denied)

ACS FINANCIAL SYSTEM
08/29/2017 11:48:35

Schedule of Bills

CITY OF WAITE PARK
GL050S-V08.05 COVERPAGE
GL540R

Report Selection:

RUN GROUP... 0817D2 COMMENT... 082917 MISC DISBURSEMENT

DATA-JE-ID DATA COMMENT

D-08282017-149 082817 MISC DISBURSEMENT

Run Instructions:

Jobq	Banner	Copies	Form	Printer	Hold	Space	LPI	Lines	CPI	CP	SP	RT
L		01			N	S	6	066	10			

Schedule of Bills

VENDOR NAME DESCRIPTION	AMOUNT	ACCOUNT NAME	FUND & ACCOUNT	CLAIM	INVOICE	PO#	F/P	ID	LINE
ALL CARE TOWING INC									
TOW SQUAD #210 TO PD	40.00	TOWING	101.4110.3910		181106	000787	P	149	00002
TOW PONTIAC-FORFEITURE	44.00	TOWING	816.4110.3910		181153	000788	P	149	00001
	84.00	*VENDOR TOTAL							
AMERICAN WATER WORK ASSN 110117-103118 MEMBERSHIP	196.00	MISC - DUES	703.4825.4010		701411735	020111	P	149	00003
ASPEN MILLS INC. UNIFORM PANTS (2)-RG	113.90	UNIFORMS	101.4110.2120		201776	000792	P	149	00004
AXON ENTERPRISE, INC SPEC BATTERIES-BODY CAM	1,460.00	CAPITAL EXPENDITURES	101.4110.5400		SI1494495	000781	P	149	00005
BOUND TREE MEDICAL LLC									
SUCTION BULB	2.91	OPERATING SUPPLIES	101.4120.2100		82564733	028302	P	149	00006
MEDICAL GLOVES	62.97	OPERATING SUPPLIES	101.4120.2100		82592971	028303	P	149	00226
	65.88	*VENDOR TOTAL							
CAL ENTERPRISE INC BATTERY #411	98.02	REPAIR & MAINTENANCE SUP	101.4212.2200		1922301006676	029014	P	149	00186
CALLYO 2009 CORP 070117-063018 ADV MOBILE	639.08	INVESTIGATIVE SUPPLIES	101.4110.2150		R8281	000793	P	149	00007
CENTRAL HYDRAULICS INC EXPANDER/ADAPTERS (7)	31.85	REPAIR & MAINTENANCE SUP	101.4212.2200		0085895	029013	P	149	00008
CENTRAL MCGOWAN INC PROPANE CYLINDER #461	195.84	REPAIR & MAINTENANCE SUP	101.4212.2200		00138349	028874	P	149	00009
CHARTER COMMUNICATIONS									
0817 INTERNET/TV CL	34.60	COMMUNICATIONS	101.4051.3100		8128081317			149	00010
0817 INTERNET/TV CH	11.01	COMMUNICATIONS	101.4094.3100		8128081317			149	00011
0817 INTERNET/TV FD	24.01	COMMUNICATIONS	101.4120.3100		8128081317			149	00012
0817 INTERNET/TV BI	34.60	COMMUNICATIONS	101.4140.3100		8128081317			149	00013
0817 INTERNET/TV PW	22.02	COMMUNICATIONS	101.4212.3100		8128081317			149	00014
0817 INTERNET/TV WTR	22.02	COMMUNICATIONS	703.4825.3100		8128081317			149	00015
0817 INTERNET/TV SWR	22.03	COMMUNICATIONS	709.4843.3100		8128081317			149	00016
0817 INTERNET/TV RADIO C	114.58	COMMUNICATIONS	101.4191.3100		8128081317			149	00017
0817 INTERNET/TV WTR	45.79	COMMUNICATIONS	703.4825.3100		8128081317			149	00018
0817 INTERNET/TV SWR	45.78	COMMUNICATIONS	709.4843.3100		8128081317			149	00019
0817 INTERNET/TV PW	143.07	COMMUNICATIONS	101.4212.3100		8128081317			149	00020
0817 INTERNET/TV PW FAC	130.08	COMMUNICATIONS	101.4212.3100		8128081317			149	00021
0817 TV PARKS	8.02	COMMUNICATIONS	101.4552.3100		8128081317			149	00022
0817 INTERNET WARMING H	89.98	COMMUNICATIONS	101.4552.3100		8128081317			149	00023
0817 TV WARMING HOUSE	8.02	COMMUNICATIONS	101.4552.3100		8128081317			149	00024
	755.61	*VENDOR TOTAL							

Schedule of Bills

VENDOR NAME	DESCRIPTION	AMOUNT	ACCOUNT NAME	FUND & ACCOUNT	CLAIM	INVOICE	PO#	F/P	ID	LINE
CITY OF ST CLOUD										
	0617 OPER & MAINT	30,493.62	OPERATIONS & MAINTENANCE	709.4842.2160		AR007586			149	00090
	0617 OPER & MAINT CONV	6,236.94	OPERATIONS & MAINTENANCE	709.4841.2160		AR007586			149	00091
	0617 REHAB & REPLACE	1,993.80	REHAB & REPLACE	709.4842.3730		AR007586			149	00092
	0617 REHAB & REPL CONV	734.56	REHAB & REPLACE	709.4841.3730		AR007586			149	00093
	0617 DEBT SVC-WWTF EXP	17,688.00	DEBT SERVICE	709.4842.4845		AR007586			149	00094
	0617 DEBT SVC-TRIS/SIS	14,321.00	DEBT SERVICE TRI-CITY/SI	709.4841.4845		AR007586			149	00095
	0617 DEBT SVC-SIS PH 3	4,552.00	DEBT SERVICE TRI-CITY/SI	709.4841.4845		AR007586			149	00096
	0617 DEBT SVC-SIS PH 4	8,669.00	DEBT SERVICE TRI-CITY/SI	709.4841.4845		AR007586			149	00097
	0617 DEBT SVC-M LIFT ST	3,485.00	DEBT SERVICE TRI-CITY/SI	709.4841.4845		AR007586			149	00098
	0617 EXISTING DEBT	2,907.78	EXISTING DEBT	709.4842.4846		AR007586			149	00099
	0717 OPER & MAINT	23,835.42	OPERATIONS & MAINTENANCE	709.4842.2160		AR007871			149	00100
	0717 OPER & MAINT CONV	5,225.16	OPERATIONS & MAINTENANCE	709.4841.2160		AR007871			149	00101
	0717 REHAB & REPLACE	1,993.80	REHAB & REPLACE	709.4842.3730		AR007871			149	00102
	0717 REHAB & REPL CONV	734.56	REHAB & REPLACE	709.4841.3730		AR007871			149	00103
	0717 DEBT SVC-WWTF EXP	17,688.00	DEBT SERVICE	709.4842.4845		AR007871			149	00104
	0717 DEBT SVC-TRI/SIS	14,321.00	DEBT SERVICE TRI-CITY/SI	709.4841.4845		AR007871			149	00105
	0717 DEBT SVC-SIS PH 3	4,552.00	DEBT SERVICE TRI-CITY/SI	709.4841.4845		AR007871			149	00106
	0717 DEBT SVC-SIS PH 4	8,669.00	DEBT SERVICE TRI-CITY/SI	709.4841.4845		AR007871			149	00107
	0717 DEBT SVC-M LIFT ST	3,485.00	DEBT SERVICE TRI-CITY/SI	709.4841.4845		AR007871			149	00108
	0717 EXISTING DEBT	2,272.54	EXISTING DEBT	709.4842.4846		AR007871			149	00109
		173,858.18	*VENDOR TOTAL							
CONVENTION VISITORS BURE										
	0717 H/M TAX - ASTERIA	2,320.23	PAYMENTS TO CHAMBER	601.4440.4441		0717			149	00230
CREATIVE CABINETS OF MN										
	FINAL PMT - COUNCIL DIAS	18,672.50	CAPITAL EXPENDITURES	101.4094.5400		612702	020123	P	149	00228
CUSTOM ACCENTS INC										
	WP T-SHIRTS-AMP/EVENTS	373.00	OFFICE SUPPLIES/POSTAGE	101.4051.2000		71664			149	00127
	BAGS-AMP BONDING PRESEN	303.11	OFFICE SUPPLIES/POSTAGE	101.4051.2000		71665			149	00128
		676.11	*VENDOR TOTAL							
DELTA DENTAL OF MN										
	1017 DENTAL PREM BB	69.24	HOSPITALIZATION INSURANC	101.4140.1500		082117	029054	P	149	00129
	1017 DENTAL PREM RS	33.84	HOSPITALIZATION INSURANC	101.4212.1500		082117	029054	P	149	00130
		103.08	*VENDOR TOTAL							
DESIGN ELECTRIC INC										
	ST LIGHT REP-WAITE/5 ST	175.57	REPAIR & MAINTENANCE SUP	101.4217.2200		5589	028602	P	149	00026
	LIGHT POLE REPL-GR OAK D	1,441.93	REPAIR & MAINTENANCE SUP	101.4217.2200		5602	028699	P	149	00025
		1,617.50	*VENDOR TOTAL							
DRIVER & VEHICLE SERVICE										
	REG 12 CHEVY TAHOE #213	11.00	DUES & SUBSCRIPTIONS	101.4110.4010		071817			149	00131
	REG 02 FD EXP PD #209	11.00	DUES & SUBSCRIPTIONS	101.4110.4010		080117			149	00132
		22.00	*VENDOR TOTAL							

Schedule of Bills

VENDOR NAME DESCRIPTION	AMOUNT	ACCOUNT NAME	FUND & ACCOUNT	CLAIM	INVOICE	PO#	F/P	ID	LINE
ELLIOTT AUTO SUPPLY CO I OIL FILTERS (3)	8.07	REPAIR & MAINTENANCE SUP	101.4212.2200		124-054553	028947	P	149	00027
EMERGENCY RESPONSE SOLUT RIT BAG REPL - TOWER 3	557.58	REPAIR & MAINTENANCE	101.4120.3700		9253	028307	P	149	00227
ERICKSON ELECTRIC COMPAN ELECTRICAL REP-GR OAK DR	8,175.50	REPAIR & MAINTENANCE	101.4217.3700		1366	020107	P	149	00029
ELECTRICAL REP-RIVERS ED	9,897.52	REPAIR & MAINTENANCE	101.4217.3700		1367	020108	P	149	00028
	18,073.02	*VENDOR TOTAL							
FASTENAL CO BINS/STEP DRILLS/ETC-WTP	328.29	REPAIR & MAINTENANCE SUP	703.4825.2200		MNST1102790	028472	P	149	00192
FLAHERTY HOOD PA 0717 LABOR/EMP SERVICES	371.25	LEGAL SERVICES	101.4060.3005		10373			149	00134
0717 BONDING SERVICE	791.00	LEGAL SERVICES	101.4060.3005		10393			149	00133
	1,162.25	*VENDOR TOTAL							
GILLELAND L/H MTR MOUNT REPL #201	398.28	REPAIR & MAINTENANCE	101.4110.3700		397849	000779	P	149	00030
GRANITE ELECTRONICS PRINTER LATCH REPL #214	25.20	REPAIR & MAINTENANCE	101.4110.3700		108000148-1	000791	P	149	00031
SPEAKER MIC REP-PV	88.28	REPAIR & MAINTENANCE-RAD	101.4110.3720		153004921-1	000772	P	149	00032
	113.48	*VENDOR TOTAL							
GRANITE WATER WORKS INC MANHOLE COVER HOOKS (3)	148.60	REPAIR & MAINTENANCE SUP	703.4822.2200		101233	028467	P	149	00033
GREAT HARVEST BREAD COMP MUFFINS/SCONES-AMP PRES	59.40	TRAINING/TRAVEL/HOTEL	101.4051.3200		3699	010089	P	149	00034
HAMMOND/JOHN VIDEO EDIT - AMP	468.75	OTHER CONTRACTUAL SERVIC	101.4051.4070		3727			149	00135
HAWKINS INC AZONE/PH DOWN LO/ETC-SP	544.84	REPAIR & MAINTENANCE SUP	101.4554.2200		4128943	028470	P	149	00036
AZONE 15/FLUORIDE-WTP	1,905.57	REPAIR & MAINTENANCE SUP	703.4822.2200		4128944	028468	P	149	00035
	2,450.41	*VENDOR TOTAL							
HENDRICKSEN PSG OFFICE CHAIRS (14)-CC	4,111.68	CAPITAL EXPENDITURES	101.4094.5400		621984	020112	P	149	00089
FURNITURE-PW FACILITY	63,483.36	CAPITAL EXPENDITURES	101.4212.5400		622437	020054	P	149	00038
OFFICE CHAIRS (5)-SJ	1,466.68	OFFICE SUPPLIES/POSTAGE	101.4094.2000		622438	020058	P	149	00037
	69,061.72	*VENDOR TOTAL							
HOME DEPOT CREDIT SERVIC ZIP TIES/TOTES/ETC-PWF	153.55	REPAIR & MAINTENANCE SUP	101.4212.2200		0012554	020113	P	149	00181

Schedule of Bills

VENDOR NAME	DESCRIPTION	AMOUNT	ACCOUNT NAME	FUND & ACCOUNT	CLAIM	INVOICE	PO#	F/P	ID	LINE
HOME DEPOT	CREDIT SERVIC									
	MULTI TAPE MEASURERS-PWF	102.90	REPAIR & MAINTENANCE SUP	101.4212.2200		0012605	028961	P	149	00182
	DRILL BITS (3) 1/8"-PWF	12.18	REPAIR & MAINTENANCE SUP	101.4212.2200		0012648	028998	P	149	00183
	DRAWER LINER-WTP	29.94	REPAIR & MAINTENANCE SUP	703.4825.2200		1012442	028474	P	149	00179
	VINYL FENCING-LIBRARY	695.00	REPAIR & MAINTENANCE SUP	101.4095.2200		1260161	028958	P	149	00180
	PLIERS/DWR LINER/ETC-WTP	76.79	REPAIR & MAINTENANCE SUP	703.4825.2200		2012361	028473	P	149	00178
	SCOTCH TAPE/SCISSOR/ETC	15.68	REPAIR & MAINTENANCE SUP	101.4094.2200		3012151	028949	P	149	00176
	DRIVER SET/ETC-WTR	532.97	REPAIR & MAINTENANCE SUP	703.4825.2200		3012233	028471	P	149	00177
	MARKING PAINT (2)/TAPE	21.52	REPAIR & MAINTENANCE SUP	101.4212.2200		4011975	020104	P	149	00175
	BRASS COUPLING-WTR TRUCK	16.25	REPAIR & MAINTENANCE SUP	101.4552.2200		6010324	028856	P	149	00174
	WIPES/TRASH CAN-PWF BATH	157.96	CAPITAL EXPENDITURES	101.4212.5400		7012999	028933	P	149	00184
	CHEST FREEZER-PW FAC	199.00	REPAIR & MAINTENANCE SUP	101.4094.2200		7260185	029001	P	149	00185
		2,013.74	*VENDOR TOTAL							
HOWE/JEFFREY R	0817 BUILDING INSP SERV	8,446.00	OTHER CONTRACTUAL SERVIC	101.4140.4070		0817			149	00136
HUHTA/COLIN	RENTAL INSPECTION REIMB	25.00	OTHER CONTRACTUAL SERVIC	101.4141.4070		39881	029131	P	149	00247
IN CONTROL INC	FLOW MTR REPLACEMENTS	24,703.20	REPAIR & MAINTENANCE SUP	703.4825.2200		17097DA01	029052	P	149	00191
INNOVATIVE OFFICE SOLUTI	FOLDERS/PEN REFILLS/ETC	36.16	OFFICE SUPPLIES/POSTAGE	101.4051.2000		IN1706565	010087	P	149	00043
	FOLDERS/PEN REFILLS/ETC	35.09	OFFICE SUPPLIES/POSTAGE	703.4825.2000		IN1706565	010087	P	149	00044
	FOLDERS/PEN REFILLS/ETC	35.09	OFFICE SUPPLIES/POSTAGE	709.4843.2000		IN1706565	010087	P	149	00045
	THERM LAM/HVY PAPER-PD	69.87	OFFICE SUPPLIES/POSTAGE	101.4110.2000		IN1709452	000785	P	149	00041
	PAPER (67#)-PD	13.99	OFFICE SUPPLIES/POSTAGE	101.4110.2000		IN1711123	000783	P	149	00040
	TONER-PD	129.99	OFFICE SUPPLIES/POSTAGE	101.4110.2000		IN1714325	000784	P	149	00039
	HVY PAPER RETURN-PD	21.82CR	OFFICE SUPPLIES/POSTAGE	101.4110.2000		SCN-063690	000785	P	149	00042
		298.37	*VENDOR TOTAL							
J P COOKE CO	2018 ANIMAL TAGS/RINGS	133.69	REPAIR & MAINTENANCE SUP	101.4196.2200		465845	029053	P	149	00047
J&K BRUGH INC	WINDOW REGL REPL #405	221.55	REPAIR & MAINTENANCE SUP	101.4212.2200		13765	028868	P	149	00046
JEFF CURTIS ELECTRIC, IN	EXHAUST MTR REPL-CH BATH	252.16	REPAIR & MAINTENANCE SUP	101.4094.2200		1889	028935	P	149	00049
	OUTLET INST-BODY CAM DOC	262.82	CAPITAL EXPENDITURES	101.4110.5400		1895	000782	P	149	00048
		514.98	*VENDOR TOTAL							
KUBIAK/KELSEY	081717 PARK RENT REFUND	59.79	REFUNDS & REIMBURSEMENT	101.4552.4980		R39888	028728	P	149	00050
LANGUAGE LINE SERVICES	0717 INTERP-SOM/SPN/VIET	337.12	PROF SERVICES - INTERPRE	101.4110.3031		4130042	000776	P	149	00051

Schedule of Bills

VENDOR NAME DESCRIPTION	AMOUNT	ACCOUNT NAME	FUND & ACCOUNT	CLAIM	INVOICE	PO#	F/P	ID	LINE
LEAGUE OF MN CITIES 092617 REG MENTAL HTH-DB	15.00	TRAINING/TRAVEL/HOTEL	101.4110.3200		092617			149	00052
LENNYS CROSSROADS AUTO, OIL CHANGE #207	40.23	REPAIR & MAINTENANCE	101.4110.3700		22510	000778	P	149	00053
LEWIS MOTOR REPAIR INC LOAD TEST GENERATOR #603	237.00	REPAIR & MAINTENANCE	709.4841.3700		0040591	028833	P	149	00054
LOAD TEST GENERATOR-CH	255.25	REPAIR & MAINTENANCE	101.4094.3700		0040592	028834	P	149	00055
	492.25	*VENDOR TOTAL							
LEXISNEXIS RISK DATA MAN 0717 MIN COMMIT BALANCE	50.00	INVESTIGATIVE SUPPLIES	101.4110.2150		1032000-201707	000775	P	149	00056
MANEY INTERNATIONAL INC DOT INSP/MAINT #441	1,713.15	REPAIR & MAINTENANCE	101.4212.3700		160829	028773	P	149	00061
DOT INSP/MAINT #443	1,422.89	REPAIR & MAINTENANCE	101.4212.3700		160981	028827	P	149	00060
DOT INSP/MAINT #410	625.33	REPAIR & MAINTENANCE	101.4212.3700		161013	029017	P	149	00059
DOT INSP #443	102.80	REPAIR & MAINTENANCE	101.4212.3700		161016	028826	P	149	00058
MUFFLER #441	114.19	REPAIR & MAINTENANCE SUP	101.4212.2200		759348	029018	P	149	00057
	3,978.36	*VENDOR TOTAL							
MARCO INC CISCO FIREWALL-PHONES	1,014.00	COMMUNICATIONS	101.4051.3100		INV4494640			149	00137
092417-092320 SHARESCAN	233.00	SERVICE CONTRACT	101.4051.4015		INV4495393			149	00138
	1,247.00	*VENDOR TOTAL							
MARK J TRAUT WELLS INC 081417 8 WATER TESTS	184.00	WATER TESTS	703.4825.4820		292227			149	00139
MARTIN MARIETTA MATERIAL CLASS 2 (19.77T)-LIBRARY	193.75	REPAIR & MAINTENANCE SUP	101.4095.2200		20933788	028851	P	149	00062
WASHED SAND (4.52)-LIB	62.15	REPAIR & MAINTENANCE SUP	101.4095.2200		20933788	028851	P	149	00063
	255.90	*VENDOR TOTAL							
MENARDS POLYSET FASTNERS (3)	20.07	REPAIR & MAINTENANCE SUP	101.4094.2200		57651	028946	P	149	00064
MULTIPLE DRILL BITS-PW	23.52	REPAIR & MAINTENANCE SUP	101.4212.2200		57679	028948	P	149	00067
TAPE MEASURER/ETC-SHOP	43.93	REPAIR & MAINTENANCE SUP	101.4212.2200		57836	028955	P	149	00065
CHAINSAW/WEED WHIP OIL	14.32	MISCELLANEOUS	101.4228.4010		57859	028954	P	149	00077
OUTLET PWR STRIPS-PW	79.70	CAPITAL EXPENDITURES	101.4212.5400		57909	028904	P	149	00068
PAPER TWL HOLDER/ETC-PWF	26.44	CAPITAL EXPENDITURES	101.4212.5400		57927	028903	P	149	00072
#STENCILS/SNAP KNIFE/ETC	23.66	REPAIR & MAINTENANCE SUP	101.4216.2200		57939	028959	P	149	00079
PATCH PLUS/KEY RAILS/ETC	33.92	CAPITAL EXPENDITURES	101.4212.5400		58003	028909	P	149	00069
DOLLY/HAND TRUCK/ETC-PWF	164.53	CAPITAL EXPENDITURES	101.4212.5400		58009	028960	P	149	00074
ANGLE BROOM/ETC-PW	91.95	CAPITAL EXPENDITURES	101.4212.5400		58019	028907	P	149	00070
HOLE SAW/FLEX TUBE/ETC	24.04	CAPITAL EXPENDITURES	101.4212.5400		58025	028908	P	149	00071
FLASH LIGHTS (4)-TRUCKS	39.99	REPAIR & MAINTENANCE SUP	101.4212.2200		58040	028962	P	149	00078
EPOXY-AMP PAPER WEIGHTS	16.41	REPAIR & MAINTENANCE SUP	101.4212.2200		58216	028999	P	149	00075

Schedule of Bills

VENDOR NAME	DESCRIPTION	AMOUNT	ACCOUNT NAME	FUND & ACCOUNT	CLAIM	INVOICE	PO#	F/P	ID	LINE
MENARDS										
	ROPE/LEVEL	19.46	REPAIR & MAINTENANCE	SUP 101.4216.2200		58248	029002	P	149	00076
	AJAX/SPONGES/ETC-PW	6.71	CAPITAL EXPENDITURES	101.4212.5400		58305	028934	P	149	00066
	SAFETY GLASSES/DRILL BIT	40.96	REPAIR & MAINTENANCE	SUP 101.4212.2200		58311	029007	P	149	00073
	WORK BENCH TOP (2)	356.00	REPAIR & MAINTENANCE	SUP 101.4212.2200		58393	029010	P	149	00080
	PRIMER/BRUSH/ETC-CH	38.35	REPAIR & MAINTENANCE	SUP 101.4094.2200		58548	029110	P	149	00081
		1,063.96	*VENDOR TOTAL							
MILLER/RICHARD E										
	0726-080217 CAR RENT-AMP	141.29	TRAINING/TRAVEL/HOTEL	101.4091.3200		D918807			149	00242
	0726-080217 CAR RENT-AMP	141.30	TRAINING/TRAVEL/HOTEL	101.4021.3200		D918807			149	00243
	0726-080217 CAR RENT-AMP	141.29	TRAINING/TRAVEL/HOTEL	101.4011.3200		D918807			149	00244
	0726-080217 CAR RENT-AMP	141.30	TRAINING/TRAVEL/HOTEL	101.4011.3200		D918807			149	00245
	0726-080217 CAR RENT-AMP	141.30	TRAINING/TRAVEL/HOTEL	101.4051.3200		D918807			149	00246
		706.48	*VENDOR TOTAL							
MN COPY SYSTEMS										
	0712-081117 PD COPIER	123.90	PRINTING & BINDING	101.4110.3400		223188			149	00086
	0712-081117 PW SHOP COPY	9.04	SERVICE CONTRACT	101.4212.4015		223479			149	00082
	0712-081117 PW SHOP COPY	5.65	SERVICE CONTRACT	703.4825.4015		223479			149	00083
	0712-081117 PW SHOP COPY	5.66	SERVICE CONTRACT	709.4843.4015		223479			149	00084
	0712-081117 PW SHOP COPY	2.26	SERVICE CONTRACTS	715.4224.4015		223479			149	00085
		146.51	*VENDOR TOTAL							
MN VALLEY TESTING LABORA										
	052317 WASTE WTR-10 AVE	139.05	SERVICE CONTRACT	709.4843.4015		865245			149	00088
	081017 WASTE WTR TESTS	352.10	SEWER TESTING	709.4843.4844		877769			149	00087
		491.15	*VENDOR TOTAL							
MOSS & BARNETT										
	0717 CHARTER FRANCHISE	18.00	LEGAL SERVICES	101.4060.3005		672406			149	00140
NATIONAL RECREATION & PA										
	110117-103118 DUES WS	170.00	MISC - DUES	101.4552.4010		103117	020110	P	149	00188
NORTHLAND SECURITIES INC										
	TIF CONSULTING	2,180.00	CONSULTANTS	101.4051.3010		5022			149	00141
OERTEL ARCHITECTS										
	PYT #18 - PW FACILITY	7,280.00	ENGINEERING COSTS	443.4214.6301		18			149	00224
	PYT #18 EXP-PW FACILITY	250.38	ENGINEERING COSTS	443.4214.6301		18			149	00225
		7,530.38	*VENDOR TOTAL							
PLAYCORE WISCONSIN, INC.										
	TOBACCO OUTPOST-PW FAC	213.59	CAPITAL EXPENDITURES	101.4212.5400		155265	028923	P	149	00110
POWERHOUSE OUTDOOR EQUIP										
	X-LINE - WEED WHIP	16.95	REPAIR & MAINTENANCE	SUP 101.4552.2200		432992	029112	P	149	00229

Schedule of Bills

VENDOR NAME	DESCRIPTION	AMOUNT	ACCOUNT NAME	FUND & ACCOUNT	CLAIM	INVOICE	PO#	F/P	ID	LINE
QUALITY APPLIANCE TV CEN	FRIDGE REPL-COMM PK PAV	899.00	REPAIR & MAINTENANCE SUP	101.4552.2200		081817	028936	P	149	00111
QUARRY CREEK NURSERY INC	GATOR/SRW GLUE-LIB	378.40	REPAIR & MAINTENANCE SUP	101.4095.2200		0080004340	028951	P	149	00113
	G SEED/PALLET RE/ETC-LIB	26.50	REPAIR & MAINTENANCE SUP	101.4095.2200		0080004435	002900	P	149	00112
		404.90	*VENDOR TOTAL							
RUSSELL/LORRAINE	0817 LANDSCAPE CONSULT	900.00	OTHER CONTRACTUAL SERVIC	101.4552.4070		0817			149	00142
SEH INC	0717 17TH AVE S PH 2	2,871.60	ENGINEERING COSTS	442.4214.6301		336897			149	00209
	0717 17TH AVE S PH 2 EXP	144.79	ENGINEERING COSTS	442.4214.6301		336897			149	00210
	0717 CLOUD PARK/6TH AVE	5,566.90	GENERAL ENGINEERING	101.4211.3015		336898/336902			149	00214
	0717 CLOUD PARK/6TH EXP	171.16	GENERAL ENGINEERING	101.4211.3015		336898/336902			149	00249
	0717 GRANITEVIEW ROAD	800.00	GENERAL ENGINEERING	101.4211.3015		336899			149	00194
	0717 AMPHITHEATER	4,165.50	GENERAL ENGINEERING	101.4211.3015		336900			149	00195
	0717 AMPHITHEATER EXP	185.48	GENERAL ENGINEERING	101.4211.3015		336900			149	00196
	0717 GIS	1,793.50	GENERAL ENGINEERING	101.4211.3015		336901			149	00197
	0717 GIS EXP	79.50	GENERAL ENGINEERING	101.4211.3015		336901			149	00198
	0717 WINDSORGREEN APTS	324.00	GENERAL ENGINEERING	101.4211.3015		336902			149	00202
	0717 SOLAR GARDEN-HELD	811.00	GENERAL ENGINEERING	101.4211.3015		336902			149	00203
	0717 TRAIL GRANT	479.50	GENERAL ENGINEERING	101.4211.3015		336902			149	00204
	0717 CITY PLANNING MTGS	609.00	GENERAL ENGINEERING	101.4211.3015		336902			149	00205
	0717 ROCK ON TRUCKS	261.00	GENERAL ENGINEERING	101.4211.3015		336902			149	00207
	0717 ROCK ON TRUCKS EXP	4.24	GENERAL ENGINEERING	101.4211.3015		336902			149	00208
	0717 CITY PLAN MTGS EXP	12.72	GENERAL ENGINEERING	101.4211.3015		336902			149	00248
	0717 SILVER LEAF HOTELS	400.00	GENERAL ENGINEERING	101.4211.3015		336904			149	00199
	0717 SILVER LF HOTELS EX	3.71	GENERAL ENGINEERING	101.4211.3015		336904			149	00200
	0717 WATER SUPPLY PLAN	675.00	WELLHEAD PROTECTION	703.4825.3013		337126			149	00213
	0717 WELL #6	6,524.50	ENGINEERING COSTS	703.4830.6301		337174			149	00211
	0717 WELL #6 EXP	90.63	ENGINEERING COSTS	703.4830.6301		337174			149	00212
	0717 M WALKER PROPERTY	174.00	GENERAL ENGINEERING	101.4211.3015		366902			149	00206
	0717 PICKLEBALL COURTS	1,206.10	GENERAL ENGINEERING	101.4211.3015		36903			149	00201
		27,353.83	*VENDOR TOTAL							
SHERWIN WILLIAMS	PAINT/ETC-STR MARKING	94.12	REPAIR & MAINTENANCE SUP	101.4216.2200		7644-0	028953	P	149	00171
	PAINT (5 GAL)-CH	224.45	REPAIR & MAINTENANCE SUP	101.4094.2200		8651-9	028905	P	149	00172
		318.57	*VENDOR TOTAL							
SHIFT TECHNOLOGIES INC	NETWORK/PRINTER SERVICE	609.96	REPAIR & MAINTENANCE	101.4051.3700		51198			149	00143
	NETWORK/PRINTER SERVICE	245.89	REPAIR & MAINTENANCE	101.4212.3700		51198			149	00144
	0817 SERVER LEASE	972.00	OTHER CONTRACTUAL SERVIC	101.4051.4070		51229			149	00193
		1,827.85	*VENDOR TOTAL							
SPECTRUM SUPPLY	SOAP DISP/ETC-STR BATH	54.50	CAPITAL EXPENDITURES	101.4212.5400		54256/570244	028928	P	149	00115

Schedule of Bills

VENDOR NAME	DESCRIPTION	AMOUNT	ACCOUNT NAME	FUND & ACCOUNT	CLAIM	INVOICE	PO#	F/P	ID	LINE
SPECTRUM SUPPLY	LINERS/TOWELS/ETC-CH	170.76	REPAIR & MAINTENANCE SUP	101.4094.2200		94125/53099	028932	P	149	00117
	TOWEL DISP (2)-PW	70.00	CAPITAL EXPENDITURES	101.4212.5400		94423	028966	P	149	00116
	LINERS/TOWELS-PW	67.68	CAPITAL EXPENDITURES	101.4212.5400		99911	028906	P	149	00114
		362.94	*VENDOR TOTAL							
ST CLOUD ACQUISITION COM	SCBA CYLINDER HYDRO TEST	27.00	REPAIR & MAINTENANCE	101.4120.3700		1204695			149	00120
ST CLOUD TIMES #1076	0917 SUBSCRIPTION	34.00	ADVERTISEMENTS	101.4051.3300		081517			149	00145
STEARNS COUNTY AUDITOR T	FORFEITURE-COUNTY PORT	145.25	MISC - TITLE FEES	816.4110.4010		16608617	000780	P	149	00118
	FORFEITURE-STATE PORT	72.73	MISC - TITLE FEES	816.4110.4010		16608617	000780	P	149	00119
		217.98	*VENDOR TOTAL							
TASC	1001-123117 COBRA FEE CL	8.97	HOSPITALIZATION INSURANC	101.4051.1500		IN1089823			149	00231
	1001-123117 COBRA FEE PL	1.96	HOSPITALIZATION INSURANC	101.4091.1500		IN1089823			149	00232
	1001-123117 COBRA FEE CH	0.98	HOSPITALIZATION INSURANC	101.4094.1500		IN1089823			149	00233
	1001-123117 COBRA FEE PD	37.34	HOSPITALIZATION INSURANC	101.4110.1500		IN1089823			149	00234
	1001-123117 COBRA FEE BI	1.96	HOSPITALIZATION INSURANC	101.4140.1500		IN1089823			149	00235
	1001-123117 COBRA FEE PW	9.81	HOSPITALIZATION INSURANC	101.4212.1500		IN1089823			149	00236
	1001-123117 COBRA FEE SN	1.84	HOSPITALIZATION INSURANC	101.4213.1500		IN1089823			149	00237
	1001-123117 COBRA FEE SS	0.42	HOSPITALIZATION INSURANC	715.4224.1500		IN1089823			149	00238
	1001-123117 COBRA FEE PK	2.37	HOSPITALIZATION INSURANC	101.4552.1500		IN1089823			149	00239
	1001-123117 COBRA FEE WT	5.22	HOSPITALIZATION INSURANC	703.4825.1500		IN1089823			149	00240
	1001-123117 COBRA FEE SW	3.50	HOSPITALIZATION INSURANC	709.4843.1500		IN1089823			149	00241
		74.37	*VENDOR TOTAL							
THE TOOL CHEST INC	TOOL BOXES/ETC-PW FAC	12,449.46	CAPITAL EXPENDITURES	101.4212.5400		D 3121	029021	P	149	00173
TOTAL RENTAL CENTER	PROPANE REFILL #461	23.28	REPAIR & MAINTENANCE SUP	101.4212.2200		213442	029005	P	149	00187
TRM3	081517 MEAL PW INTERVIEW	28.47	TRAINING/TRAVEL/HOTEL	101.4090.3200		081517	028729	P	149	00121
	081517 MEAL PW INTERVIEW	28.47	TRAINING/TRAVEL/HOTEL	101.4212.3200		081517	028729	P	149	00122
	081517 MEAL PW INTERVIEW	18.99	TRAINING/TRAVEL/HOTEL	101.4051.3200		081517	028729	P	149	00123
		75.93	*VENDOR TOTAL							
TWIN RIVER TIRE & AUTO I	TIRES REPL (4) #205	556.52	REPAIR & MAINTENANCE	101.4110.3700		G-260642	000790	P	149	00124
	TIRE REPL (1) #211	134.05	REPAIR & MAINTENANCE	101.4110.3700		G-260706	000789	P	149	00125
		690.57	*VENDOR TOTAL							
ULINE	SHARP CONTAINERS/ETC-CH	647.24	REPAIR & MAINTENANCE SUP	101.4094.2200		89239619	028927	P	149	00126

Schedule of Bills

VENDOR NAME	DESCRIPTION	AMOUNT	ACCOUNT NAME	FUND & ACCOUNT	CLAIM	INVOICE	PO#	F/P	ID	LINE
ULINE	STEEL CARTS/ECT-PW FAC	2,399.46	REPAIR & MAINTENANCE SUP	101.4094.2200		89566883	029003	P	149	00189
	STEEL CARTS/ECT-PW FAC	1,457.00	REPAIR & MAINTENANCE SUP	703.4824.2200		89566883	029003	P	149	00190
		4,503.70	*VENDOR TOTAL							
UNUM	LIFE INSURANCE COMA									
	0917 DIS PREMIUM CL	233.19	DISABILITY INS & OTHERS	101.4051.1510		081417			149	00147
	0917 DIS PREMIUM PLAN	50.29	DISABILITY INS & OTHERS	101.4091.1510		081417			149	00148
	0917 DIS PREMIUM CH	19.88	DISABILITY INS & OTHERS	101.4094.1510		081417			149	00149
	0917 DIS PREMIUM PD	884.48	DISABILITY INS & OTHERS	101.4110.1510		081417			149	00150
	0917 DIS PREMIUM BI	39.75	DISABILITY INS & OTHERS	101.4140.1510		081417			149	00151
	0917 DIS PREMIUM PW	217.90	DISABILITY INS & OTHERS	101.4212.1510		081417			149	00152
	0917 DIS PREMIUM SNOW	36.37	DISABILITY INS & OTHERS	101.4213.1510		081417			149	00153
	0917 DIS PREMIUM ST SWR	7.89	DISABILITY INS & OTHERS	715.4224.1510		081417			149	00154
	0917 DIS PREMIUM PARKS	50.13	DISABILITY INS & OTHERS	101.4552.1510		081417			149	00155
	0917 DIS PREMIUM WTR	133.69	DISABILITY INS & OTHERS	703.4825.1510		081417			149	00156
	0917 DIS PREMIUM SWR	84.64	DISABILITY INS & OTHERS	709.4843.1510		081417			149	00157
	0917 LIFE PREMIUM CL	51.73	LIFE INSURANCE	101.4051.1520		081417			149	00158
	0917 LIFE PREMIUM PLAN	11.25	LIFE INSURANCE	101.4091.1520		081417			149	00159
	0917 LIFE PREMIUM CH	5.63	LIFE INSURANCE	101.4094.1520		081417			149	00160
	0917 LIFE PREMIUM PD	214.31	LIFE INSURANCE	101.4110.1520		081417			149	00161
	0917 LIFE PREMIUM BI	11.25	LIFE INSURANCE	101.4140.1520		081417			149	00162
	0917 LIFE PREMIUM PW	56.68	LIFE INSURANCE	101.4212.1520		081417			149	00163
	0917 LIFE PREMIUM SNOW	10.69	LIFE INSURANCE	101.4213.1520		081417			149	00164
	0917 LIFE PREMIUM ST SWR	2.36	LIFE INSURANCE	715.4224.1520		081417			149	00165
	0917 LIFE PREMIUM PARKS	13.62	LIFE INSURANCE	101.4552.1520		081417			149	00166
	0917 LIFE PREMIUM WTR	30.05	LIFE INSURANCE	703.4825.1520		081417			149	00167
	0917 LIFE PREMIUM SWR	19.93	LIFE INSURANCE	709.4843.1520		081417			149	00168
		2,185.71	*VENDOR TOTAL							
VEENSTRA/BRADLEY THOMAS	0817 TELEWISE MEETINGS	300.00	LOCAL ACCESS EXPENSES	101.4051.8300		0817			149	00146
VERIZON WIRELESS SERVICE	0711-081017 PD LAPTOPS	474.04	TECHNOLOGY SERVICE CONTR	101.4110.4017		9790837180			149	00169
WEX BANK	0720-082317 FUEL BI	28.45	GAS & OIL PURCHASES	101.4140.2110		51009142			149	00215
	0720-082317 FUEL CH	532.10	GAS & OIL PURCHASES	101.4094.2110		51009142			149	00216
	0720-082317 FUEL PD	2,919.70	GAS & OIL PURCHASES	101.4110.2110		51009142			149	00217
	0720-082317 SQUAD WASHES	75.00	REPAIR & MAINTENANCE	101.4110.3700		51009142			149	00218
	0720-082317 FUEL PW	1,298.25	GAS & OIL PURCHASES	101.4212.2110		51009142			149	00219
	0720-082317 FUEL PARKS	397.15	GAS & OIL PURCHASES	101.4552.2110		51009142			149	00220
	0720-082317 FUEL WTR	363.17	GAS & OIL PURCHASES	703.4825.2110		51009142			149	00221
	0720-082317 FUEL SWR	120.15	GAS & OIL PURCHASES	709.4843.2110		51009142			149	00222
	0720-082317 FUEL FD	130.29	GAS & OIL PURCHASES	101.4120.2110		51009142			149	00223
		5,864.26	*VENDOR TOTAL							
WINDAHL TECHNOLOGY, LLC.	COMP MEMORY 8GB KIT	88.00	REPAIR & MAINT-TECHNOLOG	101.4110.3711		2315	000777	P	149	00170

ACS FINANCIAL SYSTEM
08/29/2017 11:48:36

Schedule of Bills

CITY OF WAITE PARK
GL540R-V08.05 PAGE 10

VENDOR NAME	AMOUNT	ACCOUNT NAME	FUND & ACCOUNT	CLAIM	INVOICE	PO#	F/P	ID	LINE
DESCRIPTION									
REPORT TOTALS:	408,368.22								

RECORDS PRINTED - 000249

Schedule of Bills

FUND RECAP:

FUND	DESCRIPTION	DISBURSEMENTS
101	GENERAL FUND	182,810.03
442	17TH AVE SOUTH	3,016.39
443	PUBLIC WORKS FACILITY	7,530.38
601	HOTEL MOTEL TAX	2,320.23
703	WATER FUND	37,493.17
709	SEWER FUND	174,923.11
715	STORMWATER FUND	12.93
816	DRUG FORFEITURE	261.98
TOTAL ALL FUNDS		408,368.22

BANK RECAP:

BANK	NAME	DISBURSEMENTS
CHEK	PLAZA PARK BANK	408,368.22
TOTAL ALL BANKS		408,368.22

THE PRECEDING LIST OF BILLS PAYABLE WAS REVIEWED AND APPROVED FOR PAYMENT.

DATE APPROVED BY

.....

.....

ACS FINANCIAL SYSTEM
09/13/2017 11:17:43

Schedule of Bills

CITY OF WAITE PARK
GL050S-V08.05 COVERPAGE
GL540R

Report Selection:

RUN GROUP... 0917D1 COMMENT... 091117 MISC DISBURSEMENT

DATA-JE-ID DATA COMMENT

D-09112017-156 091117 MISC DISBURSEMENT

Run Instructions:

Jobq	Banner	Copies	Form	Printer	Hold	Space	LPI	Lines	CPI	CP	SP	RT
L		01			N	S	6	066	10			

Schedule of Bills

VENDOR NAME DESCRIPTION	AMOUNT	ACCOUNT NAME	FUND & ACCOUNT	CLAIM	INVOICE	PO#	F/P	ID	LINE
ALBIN ACQUISITION CORPOR									
BACKGROUND CK-PW	45.00	OPERATING SUPPLIES	101.4212.2100		820179427S	029058	P	156	00001
BACKGROUND CK-FD	180.00	OPERATING SUPPLIES	101.4120.2100		820179427S	029058	P	156	00002
BACKGROUND CK-GAMB LIC	30.00	OPERATING SUPPLIES	101.4051.2100		820179427S	029058	P	156	00003
BACKGROUND CK-INTERN	45.00	OPERATING SUPPLIES	101.4051.2100		820179427S	029058	P	156	00004
	300.00	*VENDOR TOTAL							
ALL CARE TOWING INC									
TOW CHEVY MALIBU	44.00	TOWING	816.4110.3910		181152	000794	P	156	00005
ALL STATE COMMUNICATIONS									
SEC CAMERAS/SERVER-CH	12,087.42	CAPITAL EXPENDITURES	101.4094.5400		267439	020133	P	156	00023
ADD'L SEC CAMERAS-CH	7,017.37	CAPITAL EXPENDITURES	101.4094.5400		267440	020134	P	156	00024
	19,104.79	*VENDOR TOTAL							
ALLSTREAM BUSINESS US IN									
0823-092217 PHONES/LD-MY	22.22	COMMUNICATIONS	101.4021.3100		14847160			156	00006
0823-092217 PHONES/LD CL	117.10	COMMUNICATIONS	101.4051.3100		14847160			156	00007
0823-092217 PHONES-CH	29.32	COMMUNICATIONS	101.4094.3100		14847160			156	00008
0823-092217 PHONES/LD-PD	200.47	COMMUNICATIONS	101.4110.3100		14847160			156	00009
0823-092217 PHONES/LD-FD	23.04	COMMUNICATIONS	101.4120.3100		14847160			156	00010
0823-092217 PHONES/LD-BI	111.39	COMMUNICATIONS	101.4140.3100		14847160			156	00011
0823-092217 PHONES/LD-PW	110.52	COMMUNICATIONS	101.4212.3100		14847160			156	00012
0823-092217 PHONES-WTR	73.29	COMMUNICATIONS	703.4825.3100		14847160			156	00013
0823-092217 PHONES-SWR	73.28	COMMUNICATIONS	709.4843.3100		14847160			156	00014
0823-092217 PHONES-PD	43.06	COMMUNICATIONS	101.4110.3100		14847160			156	00015
0823-092217 PHONES-LIB	43.06	COMMUNICATIONS	101.4095.3100		14847160			156	00016
0823-092217 PHONES-WTR	129.17	COMMUNICATIONS	703.4825.3100		14847160			156	00017
0823-092217 PHONES SWR	129.16	COMMUNICATIONS	709.4843.3100		14847160			156	00018
0823-092217 PHONES PW	43.06	COMMUNICATIONS	101.4212.3100		14847160			156	00019
0823-092217 PHONES PD	20.99	COMMUNICATIONS	101.4110.3100		14847160			156	00020
0823-092217 PHONES CH	20.99	COMMUNICATIONS	101.4094.3100		14847160			156	00021
0823-092217 PHONES CH	41.98	COMMUNICATIONS	101.4094.3100		14847160			156	00022
	1,232.10	*VENDOR TOTAL							
AUTO TRIM & SIGN INC									
MULTI SIZE LETTERING-PWF	251.00	CAPITAL EXPENDITURES	101.4212.5400		48947	028950	P	156	00025
BATTERIES PLUS									
BATTERIES C (24)-FD	19.92	REPAIR & MAINTENANCE SUP	101.4120.2200		036-482224	028304	P	156	00026
BORDER STATES ELECTRIC S									
LIGHTS (36)/BALLAST-CH	149.21	REPAIR & MAINTENANCE SUP	101.4094.2200		913619435	028937	P	156	00027
CARD SERVICES									
081617 FOOD/ETC-SR COOK	34.96	COMMUNITY POLICING	101.4110.2140		946254	000801	P	156	00028
CENTRAL MCGOWAN INC									
CYL MAINT FEE (2)-PW	70.00	REPAIR & MAINTENANCE	101.4212.3700		00006450			156	00095

Schedule of Bills

VENDOR NAME DESCRIPTION	AMOUNT	ACCOUNT NAME	FUND & ACCOUNT	CLAIM	INVOICE	PO#	F/P	ID	LINE
CENTURYLINK 0725-082417 PHONE-PW FAC	107.21	COMMUNICATIONS	101.4212.3100		082517			156	00097
0817 PHONE-COMM PARK	33.29	COMMUNICATIONS	101.4552.3100		090117			156	00096
	140.50	*VENDOR TOTAL							
CITY OF ST JOSEPH WIRELESS ROUTER	275.00	CAPITAL EXPENDITURES	101.4051.5400		20170088			156	00029
COALITION OF GREATER MN 0802-080417 REG CGMC-VS	250.00	TRAINING/TRAVEL/HOTEL	101.4011.3200		080717			156	00193
COLD SPRING BAKERY ROLLS-AMP PRESENTATION	19.86	TRAINING/TRAVEL/HOTEL	101.4051.3200		197016	010092	P	156	00030
COMMISSIONER OF TRANSPOR SIGNS-17TH AVE S/PWF	5,393.40	REPAIR & MAINTENANCE SUP	101.4217.2200		082417	020132	P	156	00091
CONWAY DEUTH SCHMIESING PYT #1 - 2016 AUDIT	19,000.00	ACCOUNTING & AUDITING	101.4055.3000		240562			156	00207
CORE & MAIN LP WALL CHARGERS-AUTO GUNS	168.70	REPAIR & MAINTENANCE SUP	703.4824.2200		H622499	028469	P	156	00031
CUSTOM ACCENTS INC PENS W/CITY LOGO (1000)	487.74	EXPENSES APPROVED BY COU	601.4825.4451		71817	010091	P	156	00032
DARREL NEMETH INC 0817 ELECTRIC INSP	1,921.85	FEES PAID TO ELECTRICAL	101.4140.4080		083117			156	00033
DE LAGE LANDEN FINANCIAL 0815-091417 PD COPIER	99.23	SERVICE CONTRACT	101.4110.4015		55849117	000795	P	156	00034
0917 PW COPIER LEASE PW	42.32	SERVICE CONTRACT	101.4212.4015		56121716			156	00042
0917 PW COPIER LEASE WTR	26.45	SERVICE CONTRACT	703.4825.4015		56121716			156	00043
0917 PW COPIER LEASE SWR	26.45	SERVICE CONTRACT	709.4843.4015		56121716			156	00044
0917 PW COPIER LEASE SS	10.58	SERVICE CONTRACTS	715.4224.4015		56121716			156	00045
	205.03	*VENDOR TOTAL							
DENNE/TERRANCE E BLDG PERMIT REFUND	101.82	REFUNDS & REIMBURSEMENTS	101.4140.4980		2017-00326	029132	P	156	00035
EL-JAY MECHANICAL, INC SPRINKLER REP-CH	258.00	REPAIR & MAINTENANCE SUP	101.4094.2200		M7818-1	028938	P	156	00037
SHOWER REP-SP PAD	256.00	REPAIR & MAINTENANCE SUP	101.4554.2200		M7912-1	028484	P	156	00036
	514.00	*VENDOR TOTAL							
EMERGENCY RESPONSE SOLUT SAFETY GLASSES (12) - FD	124.60	OPERATING SUPPLIES	101.4120.2100		9278	028310	P	156	00039
HELMETS/HOODS/ETC-FD	1,641.93	CAPITAL EXPENDITURES	101.4120.5400		9288	028309	P	156	00040
FIRE DEX GLOVES XL (2)	180.20	CAPITAL EXPENDITURES	101.4120.5400		9299	028311	P	156	00038
	1,946.73	*VENDOR TOTAL							

Schedule of Bills

VENDOR NAME DESCRIPTION	AMOUNT	ACCOUNT NAME	FUND & ACCOUNT	CLAIM	INVOICE	PO#	F/P	ID	LINE
ERICKSON ELECTRIC COMPAN LIGHTS/BALLEST REPL-WTP	850.63	REPAIR & MAINTENANCE	703.4822.3700		1471	028476	P	156	00041
FASTENAL CO									
BOLTS(13)/NUTS (14)-PW	37.28	REPAIR & MAINTENANCE SUP	101.4212.2200		MNST1103153	029006	P	156	00049
FIRST AID KITS (3)-PWF	615.39	SAFETY	101.4212.2300		MNST1103191	028861	P	156	00047
BIN DIVIDERS (18)-WTR	23.36	REPAIR & MAINTENANCE SUP	703.4825.2200		MNST1103192	028486	P	156	00050
WASHERS/LOCK NUTS/ETC-PW	12.21	REPAIR & MAINTENANCE SUP	101.4212.2200		MNST1103246	029008	P	156	00048
IMPACT/BATT 20V/ETC-PWF	1,703.92	CAPITAL EXPENDITURES	101.4212.5400		MNST1103373	029012	P	156	00051
FIRST AID KIT SIGNS-PWF	92.40	REPAIR & MAINTENANCE SUP	101.4094.2200		MNST1103384	029011	P	156	00046
	2,484.56	*VENDOR TOTAL							
FLAHERTY HOOD PA									
0817 BONDING SERVICE	1,884.25	LEGAL SERVICES	101.4060.3005		10432			156	00098
0817 BONDING EXP	86.67	LEGAL SERVICES	101.4060.3005		10432			156	00099
	1,970.92	*VENDOR TOTAL							
G&K SERVICES									
0817 UNIFORMS PW	105.68	UNIFORMS	101.4212.2120		083117			156	00259
0817 UNIFORMS WTR	23.35	UNIFORMS	703.4825.2120		083117			156	00260
0817 UNIFORMS SWR	19.25	UNIFORMS	709.4843.2120		083117			156	00261
0817 TOWELS PW	8.75	RUGS/TOWELS	101.4212.4012		083117			156	00262
081017 RUGS PW	15.60	RUGS/TOWELS	101.4212.4012		6043842002			156	00248
081017 RUGS LIBRARY	7.92	RUGS/TOWELS	101.4095.4012		6043842003			156	00250
082417 RUGS CH	8.16	RUGS/TOWELS	101.4094.4012		6043853317			156	00252
082417 RUGS FD	12.72	RUGS/TOWELS	101.4120.4012		6043853317			156	00253
082417 RUGS CL	6.72	RUGS/TOWELS	101.4051.4012		6043853317			156	00254
082417 RUGS PD	15.60	RUGS/TOWELS	101.4110.4012		6043853317			156	00255
082417 RUGS PARKS	4.32	RUGS/TOWELS	101.4552.4012		6043853318			156	00256
082417 RUGS WTR	6.20	RUGS/TOWELS	703.4825.4012		6043853334			156	00257
082417 RUGS SWR	6.20	RUGS/TOWELS	709.4843.4012		6043853334			156	00258
082417 RUGS PW	29.04	RUGS/TOWELS	101.4212.4012		6043853337			156	00249
082417 RUGS LIBRARY	7.92	RUGS/TOWELS	101.4095.4012		6043853338			156	00251
	277.43	*VENDOR TOTAL							
GOPHER STATE ONE CALL IN									
0817 LOCATES WTR	87.80	EXPENSES OF GOPHER STATE	703.4825.5000		7080785			156	00052
0817 LOCATES SWR	87.80	EXPENSES OF GOPHER STATE	709.4843.5000		7080785			156	00053
	175.60	*VENDOR TOTAL							
HACH CO									
CHLOR/FLUORIDE/ETC-WTP	615.30	REPAIR & MAINTENANCE SUP	703.4822.2200		10602028/13602	028480	P	156	00054
HARDRIVES INC									
PYT #1-CLOUD PK/6TH AV S	220,944.04	CONSTRUCTION COSTS	101.4211.6300		082817			156	00310
HOT MIX (2.87T)-STR REP	136.33	REPAIR & MAINT SUPPLIES-	101.4212.2210		181196	028810	P	156	00195
TACK OIL (1)-STR REP	40.00	REPAIR & MAINTENANCE SUP	101.4552.2200		181205	028823	P	156	00194
	221,120.37	*VENDOR TOTAL							

Schedule of Bills

VENDOR NAME DESCRIPTION	AMOUNT	ACCOUNT NAME	FUND & ACCOUNT	CLAIM	INVOICE	PO#	F/P	ID	LINE
HAWKINS INC AZONE 15/FLUORIDE-WTP	1,682.88	REPAIR & MAINTENANCE SUP	703.4822.2200		4137872	028479	P	156	00055
ICON ENTERPRISES INC 1001-093018 WEBSITE FEE	1,637.03	SERVICE CONTRACT	101.4051.4015		166488	010090	P	156	00056
1001-093018 WEB HOST/SUP	3,083.78	SERVICE CONTRACT	101.4051.4015		166488	010090	P	156	00057
	4,720.81	*VENDOR TOTAL							
IN CONTROL INC WTR SCADA REMOTE ACCESS	2,811.40	REPAIR & MAINTENANCE SUP	703.4825.2200		17028DC01	020130	P	156	00058
INNOVATIVE OFFICE SOLUTI TONER/EXPO MARKERS-PD	144.73	OFFICE SUPPLIES/POSTAGE	101.4110.2000		IN1729712	000806	P	156	00059
JEFF CURTIS ELECTRIC, IN CAMERA CONDUITS INST-CH	686.56	CAPITAL EXPENDITURES	101.4094.5400		1901	020131	P	156	00060
KUE CONTRACTORS INC PYT #12-PW FACILITY	225,377.42	CONSTRUCTION COSTS	443.4214.6300		12			156	00061
LARSON EXCAVATING CONTRA PYT #9-17TH AVE S	91,030.42	CONSTRUCTION COSTS	442.4214.6300		082617			156	00196
LEAGUE OF MN CITIES 17-18 MAYORS ASSC DUES	30.00	MISC - DUES	101.4021.4010		090117			156	00198
2017-2018 DUES	7,621.00	MISC - DUES	101.4011.4010		258532			156	00199
	7,651.00	*VENDOR TOTAL							
LENNYS CROSSROADS AUTO, OIL CHANGE #213	55.32	REPAIR & MAINTENANCE	101.4110.3700		22560	000807	P	156	00062
LLRP LLC RANDOM DRUG TESTING	149.00	PROFESSIONAL SERV PHYSIC	101.4212.3011		3208	029056	P	156	00130
LMC INSURANCE TRUST DEDUCT CLAIM #C0033625	2,500.00	PROPERTY CASUALTY INSURA	101.4110.3505		2924			156	00100
M R SIGN CO INC STOP SIGNS-WOBEGON TR	118.12	REPAIR & MAINTENANCE SUP	101.4552.2200		196665	028863	P	156	00063
MULTI SIGNS (20)	308.28	REPAIR & MAINTENANCE SUP	101.4216.2200		197209	028845	P	156	00064
	426.40	*VENDOR TOTAL							
MACQUEEN EQUIPMENT INC ADAPT HOSE/ETC-VACTOR	752.71	REPAIR & MAINTENANCE SUP	709.4841.2200		P08467	028972	P	156	00065
MARCO INC 0917 CL COPIER LEASE CL	233.79	SERVICE CONTRACT	101.4051.4015		21205878			156	00077
0917 CL COPIER LEASE BI	77.93	SERVICE CONTRACT	101.4140.4015		21205878			156	00078
0917 CL COPIER LEASE WTR	38.97	SERVICE CONTRACT	703.4825.4015		21205878			156	00079
0917 CL COPIER LEASE SWR	38.96	SERVICE CONTRACT	709.4843.4015		21205878			156	00080

Schedule of Bills

VENDOR NAME	DESCRIPTION	AMOUNT	ACCOUNT NAME	FUND & ACCOUNT	CLAIM	INVOICE	PO#	F/P	ID	LINE
MARCO INC										
	0917 PHONE LEASE PD	583.38	COMMUNICATIONS	101.4110.3100		21233808			156	00066
	0917 PHONE LEASE CL	183.81	COMMUNICATIONS	101.4051.3100		21233808			156	00067
	0917 PHONE LEASE BI	75.43	COMMUNICATIONS	101.4140.3100		21233808			156	00068
	0917 PHONE LEASE CH	193.66	COMMUNICATIONS	101.4094.3100		21233808			156	00069
	0917 PHONE LEASE MAYOR	23.65	COMMUNICATIONS	101.4021.3100		21233808			156	00070
	0917 PHONE LEASE EOC	164.34	COMMUNICATIONS	101.4191.3100		21233808			156	00071
	0917 PHONE LEASE PLAN	23.65	COMMUNICATIONS	101.4091.3100		21233808			156	00072
	0917 PHONE LEASE FD	65.56	COMMUNICATIONS	101.4120.3100		21233808			156	00073
	0917 PHONE LEASE PW	89.21	COMMUNICATIONS	101.4212.3100		21233808			156	00074
	0917 PHONE LEASE WTR	28.13	COMMUNICATIONS	703.4825.3100		21233808			156	00075
	0917 PHONE LEASE SWR	47.30	COMMUNICATIONS	709.4843.3100		21233808			156	00076
		1,867.77	*VENDOR TOTAL							
MARK S DYKES										
	SWR FLUME CALIBRATIONS	544.00	REPAIR & MAINTENANCE	709.4841.3700		11677	028481	P	156	00081
	MILEAGE-SWR FLUME CALIBR	38.50	REPAIR & MAINTENANCE	709.4841.3700		11677	028481	P	156	00309
		582.50	*VENDOR TOTAL							
MARTIN MARIETTA MATERIAL										
	CLASS 2 (11.86T)-LIBRARY	116.23	REPAIR & MAINTENANCE SUP	101.4095.2200		21010612	028877	P	156	00197
MENARDS										
	BATT-CO2 DETECTORS-SQDS	101.04	REPAIR & MAINTENANCE	101.4110.3700		57663	000798	P	156	00084
	SWITCH/CABLE-PWF	15.98	REPAIR & MAINTENANCE SUP	101.4212.2200		58880	029009	P	156	00082
	HOSE/CART/NOZZLE-PWF	182.91	REPAIR & MAINTENANCE SUP	101.4094.2200		59049	028968	P	156	00085
	FLASHLIGHT/ETC-PW	82.60	REPAIR & MAINTENANCE SUP	101.4212.2200		59065	028483	P	156	00083
	WORK BENCH-PW FAC	54.99	REPAIR & MAINTENANCE SUP	101.4212.2200		59325	020124	P	156	00086
	FLASH LIGHT/BUNGEEES-WTR	65.97	REPAIR & MAINTENANCE SUP	703.4824.2200		59688	029055	P	156	00089
	SOCKETS/ETC-WTR	68.53	REPAIR & MAINTENANCE SUP	703.4824.2200		60124	028487	P	156	00088
	DISH SOAP/FEBREZE-CH	6.84	REPAIR & MAINTENANCE SUP	101.4094.2200		60176	029114	P	156	00087
		578.86	*VENDOR TOTAL							
MIDWAY IRON METAL CO INC										
	WORK BENCH DRIVE THR-PWF	1,033.50	REPAIR & MAINTENANCE SUP	101.4212.2200		362227	002886	P	156	00090
MN COPY SYSTEMS										
	0812-091117 PW COPIER PW	22.38	SERVICE CONTRACT	101.4212.4015		224737			156	00102
	0812-091117 PW COPIER WT	13.99	SERVICE CONTRACT	703.4825.4015		224737			156	00103
	0812-091117 PW COPIER SW	13.99	SERVICE CONTRACT	709.4843.4015		224737			156	00104
	0812-091117 PW COPIER SS	5.60	SERVICE CONTRACTS	715.4224.4015		224737			156	00105
	0812-091117 FD COPIER	22.29	SERVICE CONTRACT	101.4120.4015		224870			156	00101
	0812-091117 PD COPIER	92.67	PRINTING & BINDING	101.4110.3400		224921			156	00106
		170.92	*VENDOR TOTAL							
MN DEPT OF HEALTH II										
	2017 3RD QTR WTR TEST FE	3,025.77	MANDATED TEST FEE	703.4825.8200		082117			156	00200
MN DEPT OF LABORIndustr										
	17-18 ELEVATOR PERM-LIB	100.00	MISC - DUES	101.4094.4010		ALR0076527			156	00107

Schedule of Bills

VENDOR NAME DESCRIPTION	AMOUNT	ACCOUNT NAME	FUND & ACCOUNT	CLAIM	INVOICE	PO#	F/P	ID	LINE
MN POLLUTION CONTROL AGE VIC REIMB-WTP	750.00	CAPITAL EXPENDITURES	703.4822.5400		10000037190	020129	P	156	00092
MN VALLEY TESTING LABORA 082217 WASTE WTR TESTS	205.40	SEWER TESTING	709.4843.4844		879519			156	00093
MULTI MEDIA HOLDINGS COR 080417 TAX INCR DIS NOT 081017 AD 4 BIDS-GRVIEW	661.12 450.84 1,111.96	ADVERTISEMENTS ADVERTISEMENTS *VENDOR TOTAL	101.4051.3300 101.4051.3300		0004857102 0004857102			156 156	00204 00205
NORTHERN STAR THERAPY LT PRE-EMPLOY PHYSICALS-FD PRE-EMPLOY PHYSICAL-SB	236.00 59.00 295.00	PROFESSIONAL SERV PHYSIC PROFESSIONAL SERV PHYSIC *VENDOR TOTAL	101.4120.3011 101.4212.3011		9087 9087	029061 029061	P P	156 156	00108 00109
OSTENDORF/WANDA 091717 PARK RENT REFUND	59.79	REFUNDS & REIMBURSEMENT	101.4552.4980		R39969	029059	P	156	00094
PALMER PRINTING FOLDERS-AMP PRESENTATION FLYERS/SIGNS-AMP PRESENT MARKETING MATERIALS-AMP	1,088.00 935.00 393.00 2,416.00	OFFICE SUPPLIES/POSTAGE OFFICE SUPPLIES/POSTAGE OFFICE SUPPLIES/POSTAGE *VENDOR TOTAL	101.4051.2000 101.4051.2000 101.4051.2000		172144-01 172172-01 172234-01			156 156 156	00201 00202 00203
PERMITWORKS 0517 ACCESS/SUPPORT-BI 0617 ACCESS/SUPPORT-BI 0717 ACCESS/SUPPORT-BI 0817 ACCESS/SUPPORT-BI	252.92 252.92 252.92 252.92 1,011.68	OTHER CONTRACTUAL SERVIC OTHER CONTRACTUAL SERVIC OTHER CONTRACTUAL SERVIC OTHER CONTRACTUAL SERVIC *VENDOR TOTAL	101.4140.4070 101.4140.4070 101.4140.4070 101.4140.4070		2017-0077 2017-0081 2017-0086 2017-0091			156 156 156 156	00110 00111 00112 00113
POWERHOUSE OUTDOOR EQUIP OIL MIX SAW REP #E1	14.99 380.27 395.26	REPAIR & MAINTENANCE SUP REPAIR & MAINTENANCE *VENDOR TOTAL	101.4094.2200 101.4120.3700		433685 434238	029113 028312	P P	156 156	00115 00114
ROYAL TIRE INC TIRE REPL (6) #E5 TIRE REPL (6) #E2	3,373.48 2,925.96 6,299.44	REPAIR & MAINTENANCE REPAIR & MAINTENANCE *VENDOR TOTAL	101.4120.3700 101.4120.3700		328-29657 328-29663	028313 028314	P P	156 156	00117 00116
SAM'S CLUB/SYNCHRONY BAN 081617 BUS BOXES-SR CK 081617 BEANS/ETC-SR COOK	25.72 179.51 205.23	COMMUNITY POLICING COMMUNITY POLICING *VENDOR TOTAL	101.4110.2140 101.4110.2140		081117 081117	000800 000799	P P	156 156	00118 00119
SECURITY LOCKSMITHS INC PIPE CLOSET REKEY-CH	172.20	REPAIR & MAINTENANCE SUP	101.4094.2200		51488	028939	P	156	00120

Schedule of Bills

VENDOR NAME DESCRIPTION	AMOUNT	ACCOUNT NAME	FUND & ACCOUNT	CLAIM	INVOICE	PO#	F/P	ID	LINE
SHERWIN WILLIAMS									
PAINT (15GAL) -X WALKS	297.45	REPAIR & MAINTENANCE SUP	101.4216.2200		8287-7	028969	P	156	00121
PAINT (20GAL) - X WALKS	343.40	REPAIR & MAINTENANCE SUP	101.4216.2200		9145-1	028967	P	156	00122
PAINT (5GAL) RETURN	85.85CR	REPAIR & MAINTENANCE SUP	101.4216.2200		9146-9	028967	P	156	00123
	555.00	*VENDOR TOTAL							
SIMPLER/JEREMIAH									
STICKERS-HELMETS	114.99	OPERATING SUPPLIES	101.4120.2100		840151	028308	P	156	00124
ST CLOUD MEDICAL GROUP P									
PRE-EMPLOY TESTS-FD	2,139.00	PROFESSIONAL SERV PHYSIC	101.4120.3011		090117	029060	P	156	00184
PRE-EMPLOY TEST-SB	207.00	PROFESSIONAL SERV PHYSIC	101.4212.3011		090117	029060	P	156	00185
TITER TEST-PD	40.00	PROFESSIONAL SERV PHYSIC	101.4110.3011		090117	029060	P	156	00186
	2,386.00	*VENDOR TOTAL							
STEARNS COUNTY AUDITOR T									
REG 16 BOBCAT-SIDE/SIDE	8.50	MISC - DUES	101.4212.4010		090717			156	00125
STRATEGIC EQUIPMENT, LLC									
COFFEE MAKER/ETC-PWF	642.47	CAPITAL EXPENDITURES	101.4212.5400		2936760	028897	P	156	00126
THEISEN DESIGN MFG									
RAMP/STEP-HOIST PIT PWF	1,250.00	REPAIR & MAINTENANCE SUP	101.4212.2200		2925	029020	P	156	00127
THOMPSON/JASON J									
051617 MEAL - TASER TR	6.65	TRAINING/TRAVEL/HOTEL	101.4110.3200		051717			156	00128
TIERNEY BROTHERS INC									
AUDIO/VIDEO-CC	135,766.59	LOCAL ACCESS EXPENSES	101.4051.8300		499058-1			156	00210
AUDIO/VIDEO EQUIP-CC	12,763.91	LOCAL ACCESS EXPENSES	101.4051.8300		499060-1			156	00211
AUDIO/VIDEO LABOR-CC	3,600.00	LOCAL ACCESS EXPENSES	101.4051.8300		499061-1			156	00212
LOBBY SIGNAGE EQUIP	8,428.33	LOCAL ACCESS EXPENSES	101.4051.8300		499062-1			156	00208
LOBBY SIGNAGE SERVICE	150.00	LOCAL ACCESS EXPENSES	101.4051.8300		499063-1			156	00209
AUDIO/VIDEO RACKS/INS-CC	3,365.55	LOCAL ACCESS EXPENSES	101.4051.8300		509135-1			156	00213
PRICE DIFF #499062 - PWF	57.60CR	CAPITAL EXPENDITURES	101.4212.5400		639778	020109	P	156	00214
	164,016.78	*VENDOR TOTAL							
ULINE									
KEY BOX/SHELF/ETC-PWF	1,977.06	REPAIR & MAINTENANCE SUP	101.4212.2200		89691461	029015	P	156	00129
VEENSTRA/BRADLEY THOMAS									
VIDEO/PHOTOS-AMP PRESENT	800.00	OTHER CONTRACTUAL SERVIC	101.4051.4070		42520			156	00187
VERIZON WIRELESS SERVICE									
0723-082217 CELLS PD	826.28	COMMUNICATIONS	101.4110.3100		9791486347			156	00131
0723-082217 CELLS FD	16.84	COMMUNICATIONS	101.4120.3100		9791486347			156	00132
0723-082217 CELLS PLAN	60.74	COMMUNICATIONS	101.4091.3100		9791486347			156	00133
0723-082217 CELLS CL	60.74	COMMUNICATIONS	101.4051.3100		9791486347			156	00134
0723-082217 CELLS PW	115.29	COMMUNICATIONS	101.4212.3100		9791486347			156	00135
0723-082217 CELLS WTR	57.64	COMMUNICATIONS	703.4825.3100		9791486347			156	00136
0723-082217 CELLS SWR	57.64	COMMUNICATIONS	709.4843.3100		9791486347			156	00137

Schedule of Bills

VENDOR NAME	DESCRIPTION	AMOUNT	ACCOUNT NAME	FUND & ACCOUNT	CLAIM	INVOICE	PO#	F/P	ID	LINE
VERIZON WIRELESS SERVICE										
	0723-082217 BBAND PW	35.01	COMMUNICATIONS	101.4212.3100		9791487993			156	00138
	0723-082217 BBAND WTR	17.51	COMMUNICATIONS	703.4825.3100		9791487993			156	00139
	0723-082217 BBAND SWR	17.50	COMMUNICATIONS	709.4843.3100		9791487993			156	00140
	SMARTPHONE MICLOUD LIC	3,654.00	COMMUNICATIONS	101.4110.3100		9791576122			156	00215
	SMARTPHONE MICLOUD LIC	174.00	COMMUNICATIONS	101.4091.3100		9791576122			156	00216
	SMARTPHONE MICLOUD LIC	348.00	COMMUNICATIONS	101.4051.3100		9791576122			156	00217
	SMARTPHONE MICLOUD LIC	87.00	COMMUNICATIONS	101.4212.3100		9791576122			156	00218
	SMARTPHONE MICLOUD LIC	43.50	COMMUNICATIONS	703.4825.3100		9791576122			156	00219
	SMARTPHONE MICLOUD LIC	43.50	COMMUNICATIONS	709.4843.3100		9791576122			156	00220
		5,615.19	*VENDOR TOTAL							
VIKING ELECTRIC SUPPLY I	DOOR BELL-PWF	114.67	REPAIR & MAINTENANCE SUP	101.4212.2200		S000735454.001	029019	P	156	00192
VIRNIG/KARLA										
	0717 MISC MILEAGE	11.13	TRAINING/TRAVEL/HOTEL	101.4051.3200		090617			156	00141
	0817 MISC MILEAGE	19.80	TRAINING/TRAVEL/HOTEL	101.4051.3200		090617			156	00142
		30.93	*VENDOR TOTAL							
VISA										
	0917-092017 REG MN EM-DB	200.00	TRAINING/TRAVEL/HOTEL	101.4191.3200		083117			156	00143
	0917-092017 HTL/MEAL-DB	602.00	TRAINING/TRAVEL/HOTEL	101.4191.3200		083117			156	00144
	101117 REG LEAD CONF-DB	175.00	TRAINING/TRAVEL/HOTEL	101.4110.3200		083117			156	00145
	1026-102717 REG ZERO-AM	95.00	TRAINING/TRAVEL/HOTEL	101.4110.3200		083117			156	00146
	1016-101717 REG CRIME-AM	180.00	TRAINING/TRAVEL/HOTEL	101.4110.3200		083117			156	00147
	2018 MEMBERSHIP DB	25.00	DUES & SUBSCRIPTIONS	101.4110.4010		083117	000804	P	156	00148
	CERT POSTAGE-FORENSICS	9.31	INVESTIGATIVE SUPPLIES	101.4110.2150		083117	000797	P	156	00149
	TONER (2)	119.90	OFFICE SUPPLIES/POSTAGE	101.4110.2000		083117	000786	P	156	00150
	081617 MEAT SR CK-VON H	211.19	COMMUNITY POLICING	101.4110.2140		083117	000802	P	156	00151
	092717 REG SCSU CAREER D	250.00	COMMUNITY POLICING	101.4110.2140		083117	000803	P	156	00152
	082517 MEAL BODY CAM TR	50.75	TRAINING/TRAVEL/HOTEL	101.4110.3200		083117	000805	P	156	00153
	0817 BEACON FEE-WS	1.00	MISC - DUES	101.4211.4010		083117			156	00154
	MULTI ROOM SIGNS-PWF	258.88	CAPITAL EXPENDITURES	101.4212.5400		083117	020090	P	156	00155
	ADD'L ROOM SIGNS-PWF	200.00	CAPITAL EXPENDITURES	101.4212.5400		083117	020097	P	156	00156
	BOLLARD GRIPPER TABS-PWF	69.00	CAPITAL EXPENDITURES	101.4212.5400		083117	020091	P	156	00157
	FUEL ISLAND SIGN-PWF	109.67	CAPITAL EXPENDITURES	101.4212.5400		083117	020096	P	156	00158
	MARKING PAINT PENS (6)	26.78	REPAIR & MAINTENANCE SUP	101.4094.2200		083117	028882	P	156	00159
	080817 POP-AMP MEETING	39.48	TRAINING/TRAVEL/HOTEL	101.4051.3200		083117	010081	P	156	00160
	PAINT PENS (3)	12.85	REPAIR & MAINTENANCE SUP	101.4094.2200		083117	028880	P	156	00161
	PAVERS-LIBRARY	43.00	REPAIR & MAINTENANCE SUP	101.4095.2200		083117	028879	P	156	00162
	LAMINATOR/INK/ETC-PWF	509.39	CAPITAL EXPENDITURES	101.4212.5400		083117	020106	P	156	00163
	CART/ELECT CONN-SHOP	142.98	REPAIR & MAINTENANCE SUP	101.4212.2200		083117	028943	P	156	00164
	PAINT PENS (24)-SHOP	136.11	REPAIR & MAINTENANCE SUP	101.4212.2200		083117	028945	P	156	00165
	KNIVES/FORKS/ETC-PWF	86.15	CAPITAL EXPENDITURES	101.4212.5400		083117	020103	P	156	00166
	WINDOW CLEANING KIT	243.22	CAPITAL EXPENDITURES	101.4212.5400		083117	020101	P	156	00167
	BOLLARD SLEEVES (9)-PWF	355.44	CAPITAL EXPENDITURES	101.4212.5400		083117	020120	P	156	00168
	RECYCLING REC/ETC-PWF	432.26	CAPITAL EXPENDITURES	101.4212.5400		083117	020118	P	156	00169
	FLOOR CABINETS(4)-PWF	275.96	CAPITAL EXPENDITURES	101.4212.5400		083117	020102	P	156	00170
	DRY ERASE BD RET-PWF	323.46CR	CAPITAL EXPENDITURES	101.4212.5400		083117			156	00171
	SHIPPING-WATER SAMPLES	28.55	WATER TESTS	703.4825.4820		083117	028963	P	156	00172

VENDOR NAME	DESCRIPTION	AMOUNT	ACCOUNT NAME	FUND & ACCOUNT	CLAIM	INVOICE	PO#	F/P	ID	LINE
VISA	MOUSE PADS (10)-PWF	89.92	OFFICE SUPPLIES/POSTAGE	101.4212.2000		083117	020122	P	156	00173
	LITERATURE HOLDER-PWF	105.00	OFFICE SUPPLIES/POSTAGE	101.4212.2000		083117	020121	P	156	00174
	STAPLER/POSTS IT/ETC-RW	195.48	OFFICE SUPPLIES/POSTAGE	101.4212.2000		083117	028965	P	156	00175
	MICROWAVES (2)-PWF	408.00	CAPITAL EXPENDITURES	101.4212.5400		083117	020116	P	156	00176
	PAPER SHREDDERS (2)-PWF	215.00	OFFICE SUPPLIES/POSTAGE	101.4212.2000		083117	029016	P	156	00177
	MICROWAVES (2)/HDMI-PWF	434.84	CAPITAL EXPENDITURES	101.4212.5400		083117	020117	P	156	00178
	091117 REG AWWA CONF-WS	245.00	TRAINING/TRAVEL/HOTEL	703.4825.3200		083117			156	00179
	PAPER CLIPS/FOLDERS/ETC	216.51	OFFICE SUPPLIES/POSTAGE	101.4212.2000		083117	029022	P	156	00180
	WALL CLOCK-PWF	38.46	CAPITAL EXPENDITURES	101.4212.5400		083117	020125	P	156	00181
	HOIST/CLEVIS/ETC-WTP	265.95	REPAIR & MAINTENANCE SUP	703.4825.2200		083117	029023	P	156	00182
	DRUM FAN	149.99	REPAIR & MAINTENANCE SUP	703.4822.2200		083117	020127	P	156	00183
	072917 MEAL AMP TOUR-BH	10.22	TRAINING/TRAVEL/HOTEL	101.4091.3200		083117			156	00263
	072917 MEAL AMP TOUR-RM	10.22	TRAINING/TRAVEL/HOTEL	101.4021.3200		083117			156	00264
	072917 MEAL AMP TOUR-CS	10.22	TRAINING/TRAVEL/HOTEL	101.4011.3200		083117			156	00265
	072917 MEAL AMP TOUR-FT	10.22	TRAINING/TRAVEL/HOTEL	101.4011.3200		083117			156	00266
	072917 MEAL AMP TOUR-SJ	10.22	TRAINING/TRAVEL/HOTEL	101.4051.3200		083117			156	00267
	0817 PW HIRING AD	68.75	ADVERTISEMENTS	101.4212.3300		083117			156	00268
	0802-080317 HTL CGMC-VS	220.72	TRAINING/TRAVEL/HOTEL	101.4011.3200		083117			156	00269
	CARD HOLDERS-AMP PRES	21.98	OFFICE SUPPLIES/POSTAGE	101.4051.2000		083117			156	00270
	080717 MEAL RM - AMP MTG	14.45	TRAINING/TRAVEL/HOTEL	101.4021.3200		083117			156	00271
	080717 MEAL BS - AMP MTG	14.45	TRAINING/TRAVEL/HOTEL	101.4212.3200		083117			156	00272
	080717 MEAL JN - AMP MTG	15.05	TRAINING/TRAVEL/HOTEL	101.4091.3200		083117			156	00273
	080717 MEAL SJ - AMP MTG	14.75	TRAINING/TRAVEL/HOTEL	101.4051.3200		083117			156	00274
	080717 MEALS N WEST-AMP	37.63	TRAINING/TRAVEL/HOTEL	101.4051.3200		083117			156	00275
	WTR PITCHERS/COASTERS-PW	70.81	CAPITAL EXPENDITURES	101.4212.5400		083117			156	00276
	080817 MEALS - AMP MTG	110.22	TRAINING/TRAVEL/HOTEL	101.4051.3200		083117	010084	P	156	00277
	080817 MEAL CS - AMP MTG	10.02	TRAINING/TRAVEL/HOTEL	101.4011.3200		083117	010084	P	156	00278
	080817 MEAL RM - AMP MTG	10.02	TRAINING/TRAVEL/HOTEL	101.4021.3200		083117	010084	P	156	00279
	080817 MEAL BS - AMP MTG	10.02	TRAINING/TRAVEL/HOTEL	101.4212.3200		083117	010084	P	156	00280
	080817 MEAL JN - AMP MTG	10.02	TRAINING/TRAVEL/HOTEL	101.4091.3200		083117	010084	P	156	00281
	080817 FOOD-NEW WEST/AMP	16.35	TRAINING/TRAVEL/HOTEL	101.4051.3200		083117			156	00282
	080817 MEAL RM - AMP MTG	14.69	TRAINING/TRAVEL/HOTEL	101.4021.3200		083117			156	00283
	080817 MEALS FT/CS-AMP	28.15	TRAINING/TRAVEL/HOTEL	101.4011.3200		083117			156	00284
	080817 MEAL SJ - AMP MTG	19.59	TRAINING/TRAVEL/HOTEL	101.4051.3200		083117			156	00285
	080817 MEALS N WEST-AMP	42.84	TRAINING/TRAVEL/HOTEL	101.4051.3200		083117			156	00286
	SILVERWARE TRAY - PWF	10.73	CAPITAL EXPENDITURES	101.4212.5400		083117	020119	P	156	00287
	1020-102617 REG ICMA SJ	773.00	TRAINING/TRAVEL/HOTEL	101.4051.3200		083117			156	00288
	COFFEE/TOWEL HOLDERS-PWF	23.47	REPAIR & MAINTENANCE SUP	101.4212.2200		083117	020114	P	156	00289
	081517 FOOD/ETC-AMP PRES	64.09	TRAINING/TRAVEL/HOTEL	101.4051.3200		083117			156	00290
	FOOD-AMP PRESENTATION	11.84	TRAINING/TRAVEL/HOTEL	101.4051.3200		083117			156	00291
	FOODS/PLANTS - AMP PRES	23.58	TRAINING/TRAVEL/HOTEL	101.4051.3200		083117	010088	P	156	00292
	WALL FILE/KEYBOARDS-PWF	106.84	OFFICE SUPPLIES/POSTAGE	101.4212.2000		083117	020115	P	156	00293
	LABELS-AMP PRESENTATION	36.06	OFFICE SUPPLIES/POSTAGE	101.4051.2000		083117			156	00294
	SUPPLIES-AMP PRESENTATION	63.74	OFFICE SUPPLIES/POSTAGE	101.4051.2000		083117			156	00295
	0817 BEACON FEE	1.00	MISC - DUES	101.4051.4010		083117			156	00296
	081517 FOOD/ETC-AMP PRES	58.44	TRAINING/TRAVEL/HOTEL	101.4051.3200		083117			156	00297
	SUPPLIES - AMP PRES	43.56	OFFICE SUPPLIES/POSTAGE	101.4051.2000		083117			156	00298
	0717-081617 MS ONLINE CL	231.00	SERVICE CONTRACT	101.4051.4015		083117			156	00299
	0717-081617 MS ONLINE FD	99.00	SERVICE CONTRACT	101.4120.4015		083117			156	00300
	0717-081617 MS ONLINE BI	66.00	SERVICE CONTRACT	101.4140.4015		083117			156	00301

Schedule of Bills

VENDOR NAME	DESCRIPTION	AMOUNT	ACCOUNT NAME	FUND & ACCOUNT	CLAIM	INVOICE	PO#	F/P	ID	LINE
VISA										
	0717-081617 MS ONLINE PW	165.00	SERVICE CONTRACT	101.4212.4015		083117			156	00302
	0717-081617 MS ONLINE WT	99.00	SERVICE CONTRACT	703.4825.4015		083117			156	00303
	0821-092017 ADOBE SUB SJ	75.15	OTHER CONTRACTUAL SERVIC	101.4051.4070		083117			156	00304
	0821-092017 ADOBE SUB MW	75.15	OTHER CONTRACTUAL SERVIC	101.4051.4070		083117			156	00305
	IPAD/PHONE CORD - SJ	12.99	OFFICE SUPPLIES/POSTAGE	101.4051.2000		083117			156	00306
	0927-092917 MNAPA CON-JN	300.00	TRAINING/TRAVEL/HOTEL	101.4091.3200		083117			156	00307
	TAPE CARTRIDGE	151.88	REPAIR & MAINTENANCE SUP	101.4051.2200		083117	028720	P	156	00308
		10,222.69	*VENDOR TOTAL							
WEST CENTRAL SANITATION										
	0817 REFUSE 1550 PICKUPS	26,126.72	OTHER CONTRACTUAL SERVIC	101.4223.4070		083117			156	00206
	0817 3 COMPOST DUMPSTERS	300.00	OTHER CONTRACTUAL SERVIC	101.4223.4070		10992247			156	00188
		26,426.72	*VENDOR TOTAL							
WINDAHL TECHNOLOGY, LLC.										
	ETHERNET LINE INST-BDY C	298.50	CAPITAL EXPENDITURES	101.4110.5400		2323	000796	P	156	00189
	ENTHERNET LINE PARTS-BDY	188.64	CAPITAL EXPENDITURES	101.4110.5400		2323	000796	P	156	00190
		487.14	*VENDOR TOTAL							
WSI OF MN INC										
	081717 WEED CUT-223 6 AV	130.00	REPAIR & MAINTENANCE	101.4227.3700		08302017	029057	P	156	00191
XCEL ENERGY										
	0720-082017 GILLITZER	67.40	PUBLIC UTILITY SERVICES	101.4094.3600		558783869			156	00225
	0723-082117 GREAT OAK DR	154.63	PUBLIC UTILITY SERVICES	101.4217.3600		558908342			156	00223
	0723-082117 NEW WTP	7,316.27	PUBLIC UTILITY SERVICES	703.4822.3600		559248446			156	00226
	0725-082317 860 17 AVE S	25.02	PUBLIC UTILITY SERVICES	101.4217.3600		559324638			156	00224
	0804-090317 ST LIGHTS	6,911.63	PUBLIC UTILITY SERVICES	101.4217.3600		560531170			156	00222
	0722-081917 PW FACILITY	2,998.00	PUBLIC UTILITY SERVICES	101.4212.3600		560623283			156	00221
	0720-082017 WTR TOWERS	382.05	PUBLIC UTILITY SERVICES	703.4824.3600		560729606			156	00227
	0723-082117 SWR LIFT ST	312.95	PUBLIC UTILITY SERVICES	709.4841.3600		560729606			156	00228
	0722-082117 PARKS	1,981.69	PUBLIC UTILITY SERVICES	101.4552.3600		560729606			156	00229
	0723-082117 RIVERS EDGE	21.88	PUBLIC UTILITY SERVICES	101.4552.3600		560729606			156	00230
	0723-082117 BARTZ PARK	11.80	PUBLIC UTILITY SERVICES	101.4552.3600		560729606			156	00231
	0723-082117 CITY GARAGES	721.50	PUBLIC UTILITY SERVICES	101.4552.3600		560729606			156	00232
	0723-082117 WELLHOUSES	100.49	PUBLIC UTILITY SERVICES	703.4822.3600		560729606			156	00233
	0723-082117 OLD WTP	92.57	PUBLIC UTILITY SERVICES	703.4822.3600		560729606			156	00234
	0720-082017 TRAFF SIGNAL	576.35	PUBLIC UTILITY SERVICES	101.4216.3600		560729606			156	00235
	0722-082117 CITY HALL	633.30	PUBLIC UTILITY SERVICES	101.4094.3600		560729606			156	00236
	0722-082117 CITY HALL	81.72	PUBLIC UTILITY SERVICES	101.4051.3600		560729606			156	00237
	0722-082117 CITY HALL	388.15	PUBLIC UTILITY SERVICES	101.4120.3600		560729606			156	00238
	0722-082117 CITY HALL	878.45	PUBLIC UTILITY SERVICES	101.4110.3600		560729606			156	00239
	0722-082117 CITY HALL	20.43	PUBLIC UTILITY SERVICES	101.4140.3600		560729606			156	00240
	0722-082117 CITY HALL	20.43	PUBLIC UTILITY SERVICES	703.4825.3600		560729606			156	00241
	0722-082117 CITY HALL	20.42	PUBLIC UTILITY SERVICES	709.4843.3600		560729606			156	00242
	0723-082117 LIBRARY	345.17	PUBLIC UTILITY SERVICES	101.4095.3600		560729606			156	00243
	0723-082017 ST LIGHTS	647.99	PUBLIC UTILITY SERVICES	101.4217.3600		560729606			156	00244
	0730-082717 810 3 ST N	8.58	PUBLIC UTILITY SERVICES	101.4217.3600		560729606			156	00245
	0722-082117 SPLASH PAD	1,616.84	PUBLIC UTILITY SERVICES	101.4554.3600		560729606			156	00246
	0720-082017 201 3 ST N	16.35	PUBLIC UTILITY SERVICES	101.4094.3600		560729606			156	00247

ACS FINANCIAL SYSTEM
09/13/2017 11:17:43

Schedule of Bills

CITY OF WAITE PARK
GL540R-V08.05 PAGE 11

VENDOR NAME	DESCRIPTION	AMOUNT	ACCOUNT NAME	FUND & ACCOUNT	CLAIM	INVOICE	PO#	F/P ID	LINE
XCEL ENERGY		26,352.06	*VENDOR TOTAL						

ACS FINANCIAL SYSTEM
09/13/2017 11:17:43

Schedule of Bills

CITY OF WAITE PARK
GL540R-V08.05 PAGE 12

VENDOR NAME	AMOUNT	ACCOUNT NAME	FUND & ACCOUNT	CLAIM	INVOICE	PO#	F/P ID LINE
DESCRIPTION							
REPORT TOTALS:	878,648.43						

RECORDS PRINTED - 000310

Schedule of Bills

FUND RECAP:

FUND	DESCRIPTION	DISBURSEMENTS
101	GENERAL FUND	539,948.82
442	17TH AVE SOUTH	91,030.42
443	PUBLIC WORKS FACILITY	225,377.42
601	HOTEL MOTEL TAX	487.74
703	WATER FUND	19,308.84
709	SEWER FUND	2,435.01
715	STORMWATER FUND	16.18
816	DRUG FORFEITURE	44.00
TOTAL ALL FUNDS		878,648.43

BANK RECAP:

BANK	NAME	DISBURSEMENTS
CHEK	PLAZA PARK BANK	878,648.43
TOTAL ALL BANKS		878,648.43

THE PRECEDING LIST OF BILLS PAYABLE WAS REVIEWED AND APPROVED FOR PAYMENT.

DATE APPROVED BY
.....
.....

Agenda Item No. 10

Issue: Administrator Update

Updates will be presented at the time of the meeting.

ADJOURNMENT

Respectfully submitted,

Shaunna Johnson, Administrator